

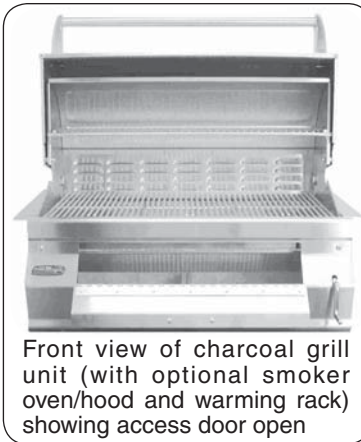

# CHARCOAL LEGACY GRILL

**12 & 14 BUILT-IN SERIES**  
**22 & 24 STAND ALONE SERIES**



Front view of charcoal grill unit (with optional smoker oven/hood and warming rack) showing access door open



Stand alone charcoal grill (with optional smoker oven/hood)

## FOR YOUR SAFETY

Do not store or use gasoline or other flammable vapors and liquids in the vicinity of this or any other appliance.

## INSTALLATION OPENING REQUIREMENTS

**12 Series:** 19 3/4" depth, 26 1/4" width, 12" height  
**14 Series:** 19 3/4" depth, 32 1/4" width, 12" height

The grill serial identification number is located on the underside of the drip tray handle. It is recommended that the drip tray first be removed and cleaned / emptied of its contents, then turned over to view.

The Fire Magic® stainless steel charcoal grill has the benefit of an adjustable height charcoal pan allowing you to change the height of the charcoal while cooking and gives you the ability to add fuel without having to remove the cooking grids. This enables the outdoor chef to be in complete control of cooking heat at the grilling surface.

## WARNING

Built-in models **must** be installed in masonry or other type of fireproof enclosure. The unit is not insulated and therefore **must** be installed with 18" of side and back clearance from unprotected combustible materials such as wood, plastic or stucco with wood framing.

The unit **must** have a minimum of 4" right, left, and rear clearance from any non-combustible wall (or backsplash) for proper ventilation and to prevent dangerous overheating. **If a smoker hood is installed, the rear clearance must be 11" to allow the hood to open.**

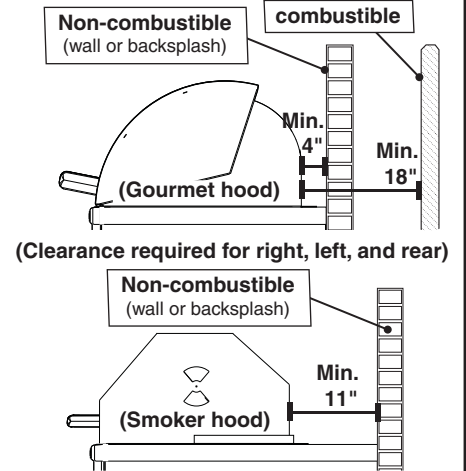

**Do not install this unit under unprotected flammable surfaces. Do not install or use this appliance inside a building, garage, or any other enclosed area, including recreational vehicles or boats.**

Carefully unpack your grill and check the parts. If you have purchased a built-in, simply slide the unit into your grill opening. Next, fit the crank handle into the hole on the front right side of the face. Aligning it carefully, screw it into the nut on the frame (see Fig. 1-1). After installation, crank the handle in and out to raise and lower the charcoal pan.

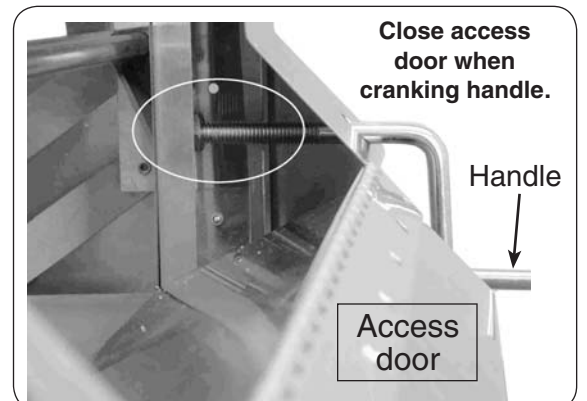

**Fig. 1-1 Installing the crank handle**

## INSTALLATION

### **WARNING**

Improper installation, adjustment, alteration, service, or maintenance can cause injury or property damage. Refer to this manual. For assistance or additional information, consult a qualified professional installer or service agency.

### **CHARCOAL GRILL OVEN (optional)**

If you purchased an oven with your charcoal grill it will come pre-assembled from the factory.

The oven (with the rounded top Fig. 2-1) is easy to remove and replace. Simply remove the cooking grids and lift the oven off of the grill, then replace the cooking grids. To reinstall reverse the above process.

The smoker model oven has an angled lid and adjustable air vents to aid in controlling the rate at which the charcoal burns. The oven may be lifted off after removing the left and right retaining screws (Fig. 2-2) on the inside of the oven.

Clean all surfaces with **Fire Magic® foaming grill cleaner**.

**For stainless steel restoration and finish maintenance**, see the instructions enclosed with Fire Magic® products for stainless steel.

**Ashes and dripping are removed by sliding the drip tray out from beneath the grill. You must keep the drip tray heat shield in position for proper operation.**

Fig. 2-1



Fig. 2-2

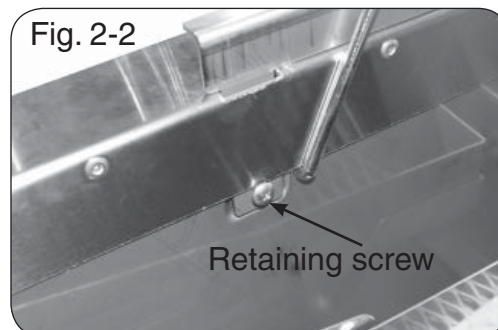

## USING THE GOURMET STAINLESS STEEL CHARCOAL GRILL

1. Remove the cooking grids and pile your charcoal on the charcoal pan. Avoid spillage.

**WARNING:** When adding charcoal, spread it across the charcoal pan evenly and DO NOT exceed a height of 1" above the charcoal pan.

Excessive amounts of charcoal may cause over heating and damage to your grill.

2. Follow the instructions supplied with your charcoal/fuel for lighting.

3. Turning the crank handle raises or lowers the charcoal pan to increase or decrease the grilling heat as you desire.

4. Lower the charcoal pan and open the access door to add or spread out your coals while cooking.

### **WARNING**

All surfaces of the charcoal unit become HOT during use. Exercise caution when using this unit, especially when adding charcoal or cranking the charcoal pan up or down.

### **EXHAUST REMOVAL**

If installed under a patio roof, the grill area should be fully covered by a non-combustible chimney and exhaust hood. An exhaust fan with a rating of 1,000 CFM or more is necessary to efficiently remove smoke and other cooking by-products from the covered area.

**THIS UNIT SHOULD NOT BE LOCATED IN A FULLY ENCLOSED AREA OF ANY KIND.**

# GOURMET BUILT-IN PARTS LIST

CUSTOM I		
Item no.	Part no.	Description
1.	23729	Gourmet hood (optional)
2.	3542-DS-2	Cooking grids, Diamond Sear (2)
3.	3302-S	Charcoal pan
4.	400363	Liner assembly
5.	3137-06	Face
6.	3900-40	Handle only
7.	23302	Crank
8.	3081	Drip tray
9.	3672S	Gourmet warming rack (optional)

REGAL I		
Item no.	Part no.	Description
1.	23733	Gourmet hood (optional)
2.	3543-DS-3	Cooking grids, Diamond Sear (3)
3.	3304-S	Charcoal pan (2)
4.	400364	Liner assembly
5.	3162-06	Face
6.	3900-40	Handle only
7.	23302	Crank
8.	3082	Drip tray
9.	3673S	Gourmet warming rack (optional)

Replacement parts can be ordered from your local Fire Magic® dealer.

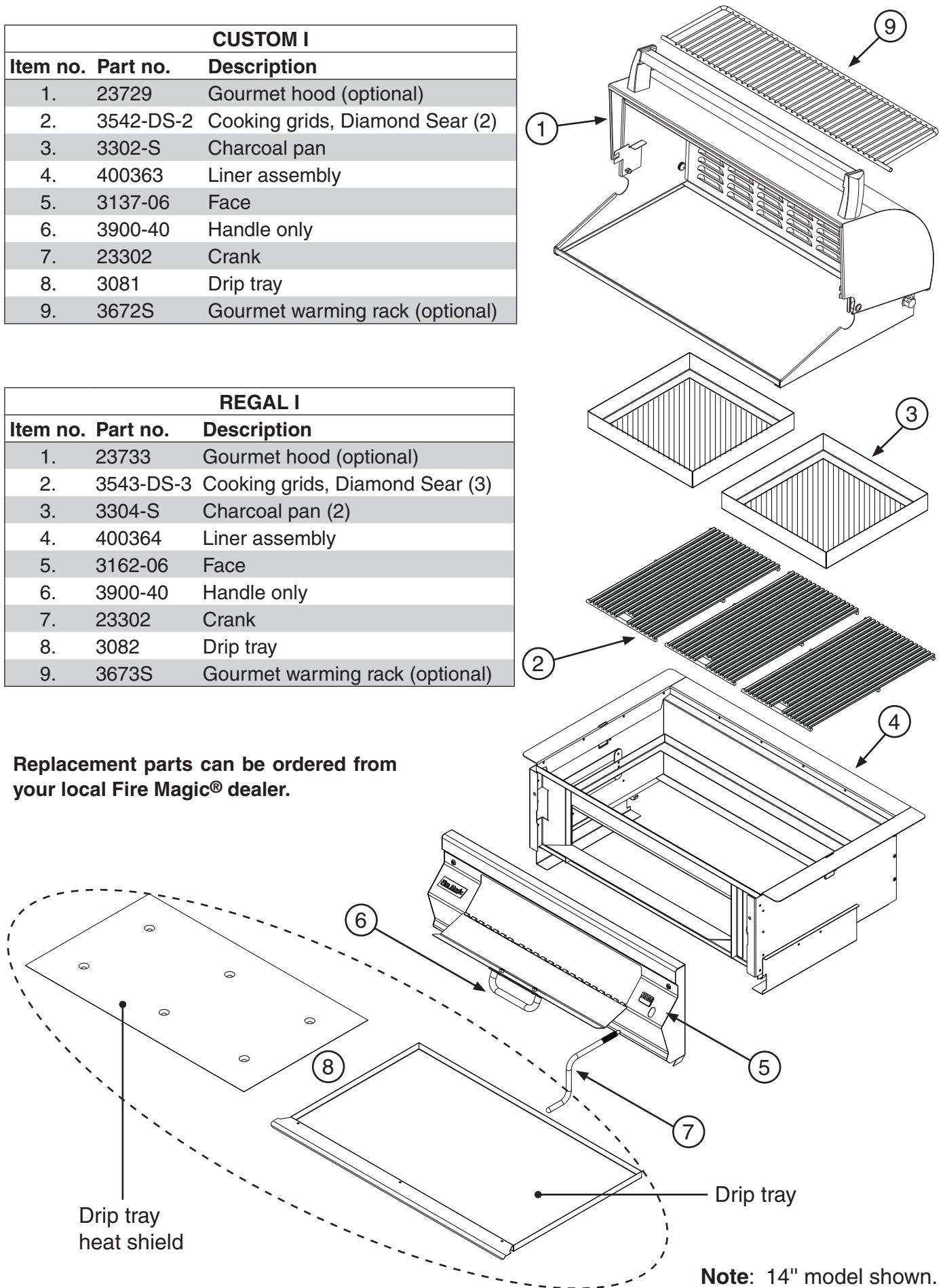

Note: 14" model shown.

# SMOKER BUILT-IN PARTS LIST

## CUSTOM I

Item no.	Part no.	Description
1.	23759-C	Smoker hood
2.	3542-DS-2	Cooking grids, Diamond Sear (2)
3.	3305	Charcoal shield
4.	3302-S	Charcoal pan
5.	400363	Liner assembly
6.	3137-06	Face
7.	3900-40	Handle only
8.	23302	Crank
9.	3081	Drip tray
10.	3672C	Gourmet warming rack

## REGAL I

Item no.	Part no.	Description
1.	23763-C	Smoker hood
2.	3543-DS-3	Cooking grids, Diamond Sear (3)
3.	3305	Charcoal shield
4.	3304-S	Charcoal pan (2)
5.	400364	Liner assembly
6.	3162-06	Face
7.	3900-40	Handle only
8.	23302	Crank
9.	3082	Drip tray
10.	3673C	Gourmet warming rack

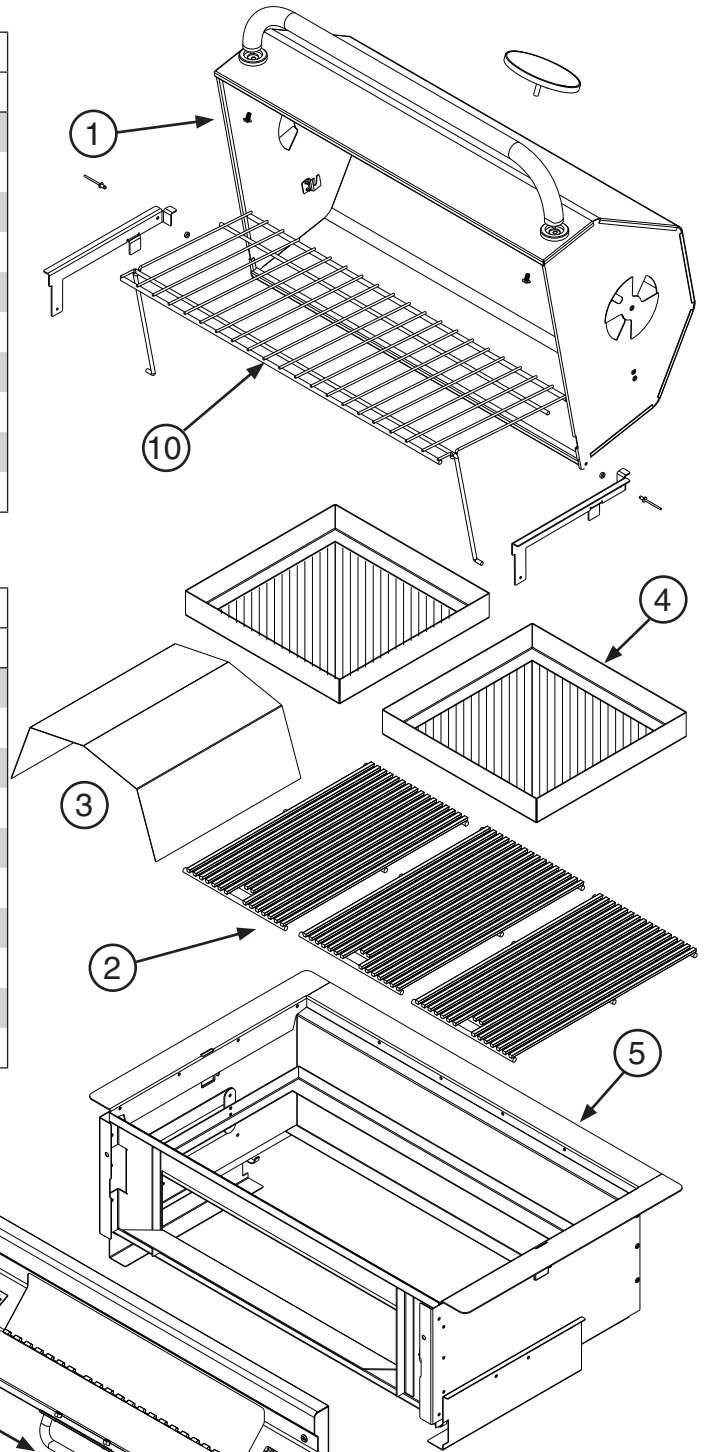

Replacement parts can be ordered from your local Fire Magic® dealer.

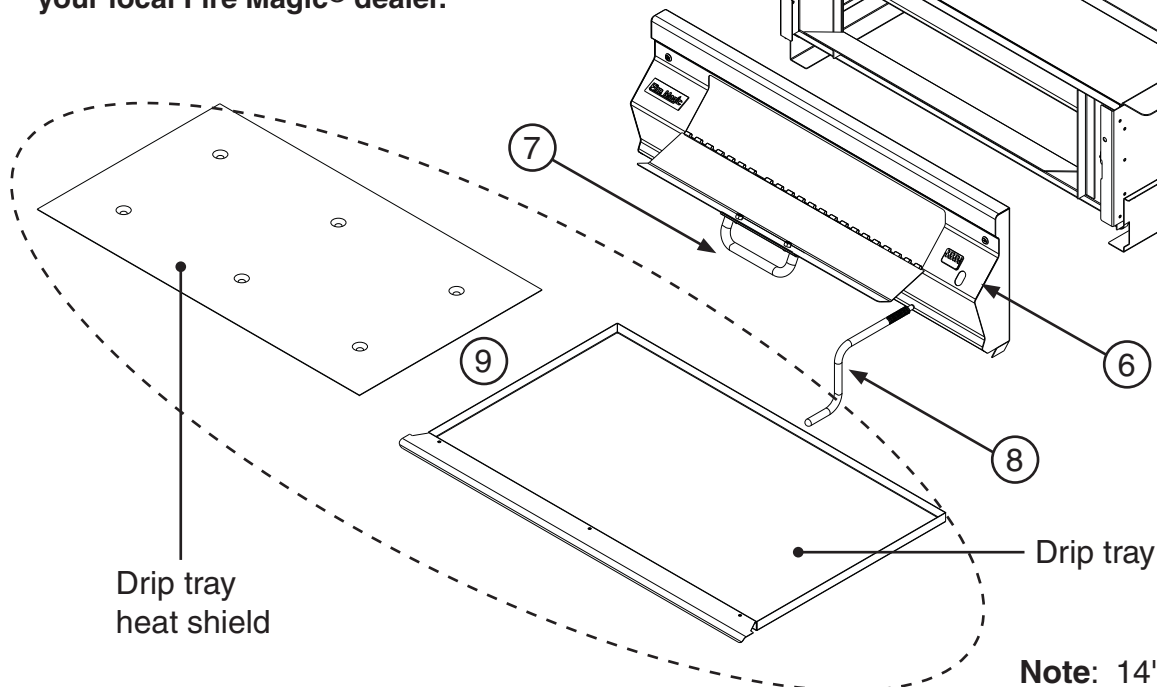

Note: 14" model shown.

# GOURMET STAND ALONE PARTS LIST

## CUSTOM I

Item no.	Part no.	Description
1.	23729	Gourmet hood
2.	3542-DS-2	Cooking grids, Diamond Sear (2)
3.	3302-S	Charcoal pan
4.	400365	Liner assembly
5.	25326-015	Shelves
6.	25326-014	Cart base
7.	3400-7	Casters set only
8.	3137-06	Face
9.	3900-40	Handle only
10.	23302	Crank
11.	3081	Drip tray assembly
12.	3672S	Gourmet warming rack (optional)

Replacement parts can be ordered from your local Fire Magic® dealer.

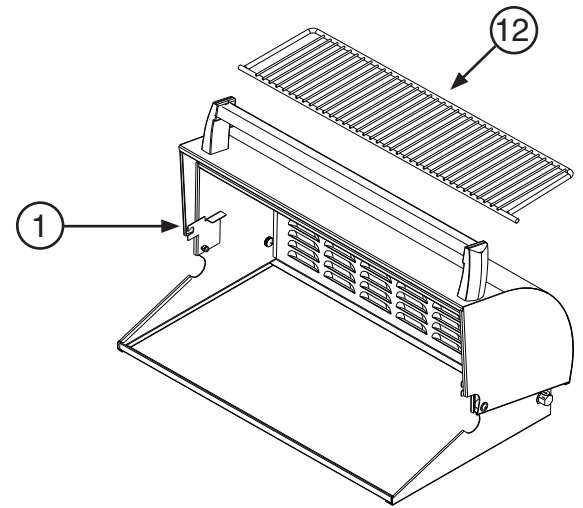

## REGAL I

Item no.	Part no.	Description
1.	23733	Gourmet hood
2.	3543-DS-3	Cooking grids, Diamond Sear (3)
3.	3304-S	Charcoal pan (2)
4.	400366	Liner assembly
5.	25326-015	Shelves
6.	25361-014	Cart base
7.	3400-7	Casters set only
8.	3162-06	Face
9.	3900-40	Handle only
10.	23302	Crank
11.	3082	Drip tray assembly
12.	3673S	Gourmet warming rack (optional)

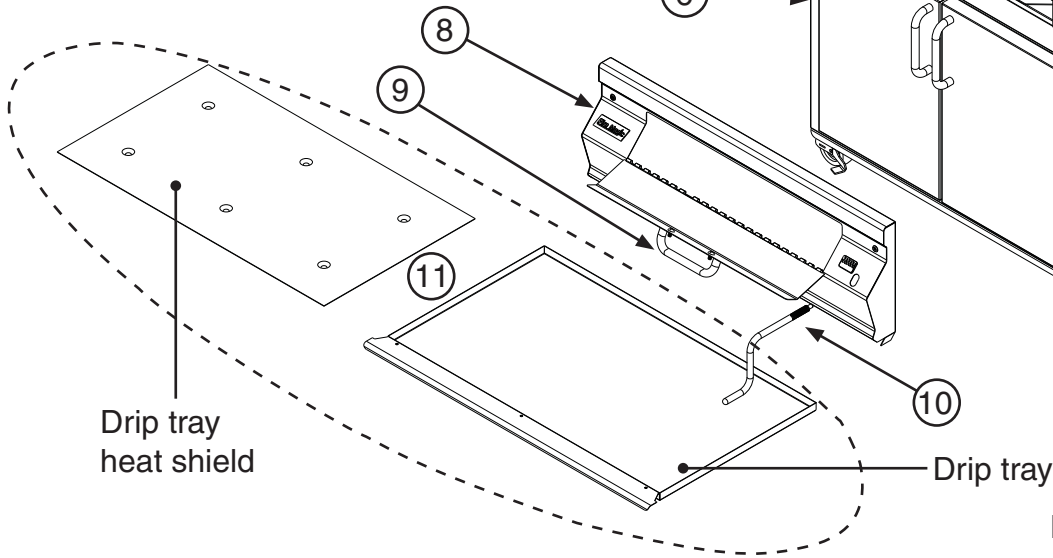
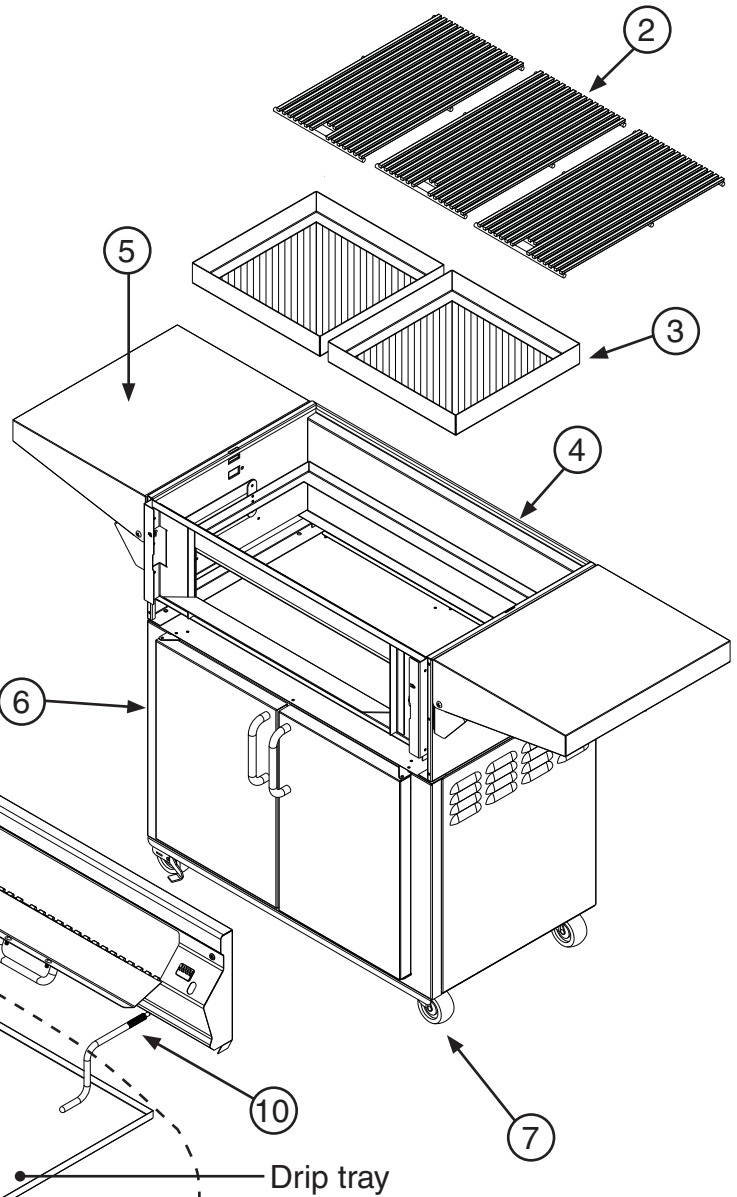

Note: 24" model shown.

# SMOKER STAND ALONE PARTS LIST

## CUSTOM I

Item no.	Part no.	Description
1.	23759-C	Smoker hood
2.	3542-DS-2	Cooking grids, Diamond Sear (2)
3.	3305	Charcoal shield
4.	3302-S	Charcoal pan
5.	400365	Liner assembly
6.	25326-015	Shelves
7.	25326-014	Cart base
8.	3400-7	Casters set only
9.	3137-06	Face
10.	3900-40	Handle only
11.	23302	Crank
12.	3081	Drip tray assembly
13.	3672C	Gourmet warming rack

Replacement parts can be ordered from your local Fire Magic® dealer.

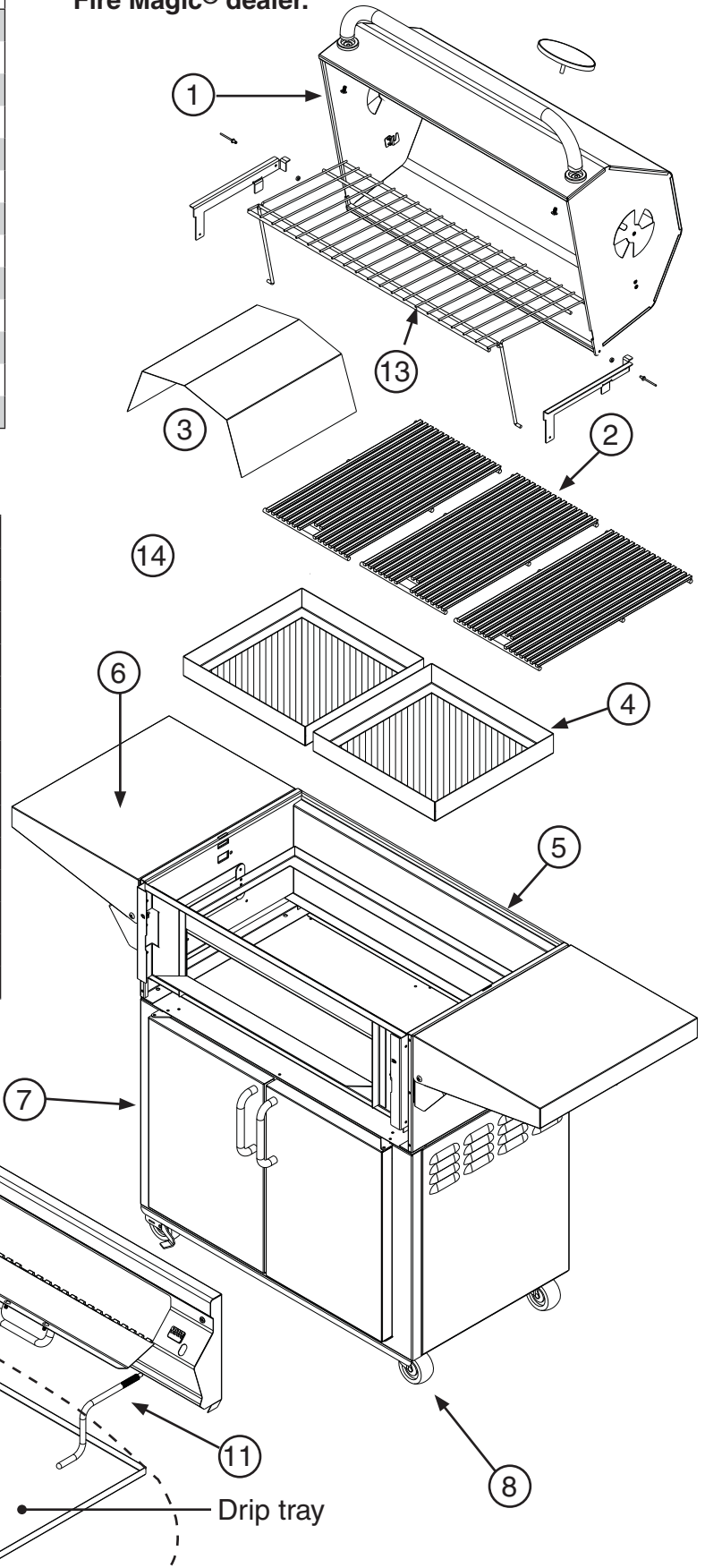

## REGAL I

Item no.	Part no.	Description
1.	23763-C	Smoker hood
2.	3543-DS-3	Cooking grids, Diamond Sear (3)
3.	3305	Charcoal shield
4.	3304-S	Charcoal pan (2)
5.	400366	Liner assembly
6.	25326-015	Shelves
7.	25361-014	Cart base
8.	3400-7	Casters set only
9.	3162-06	Face
10.	3900-40	Handle only
11.	23302	Crank
12.	3082	Drip tray assembly
13.	3673C	Gourmet warming rack

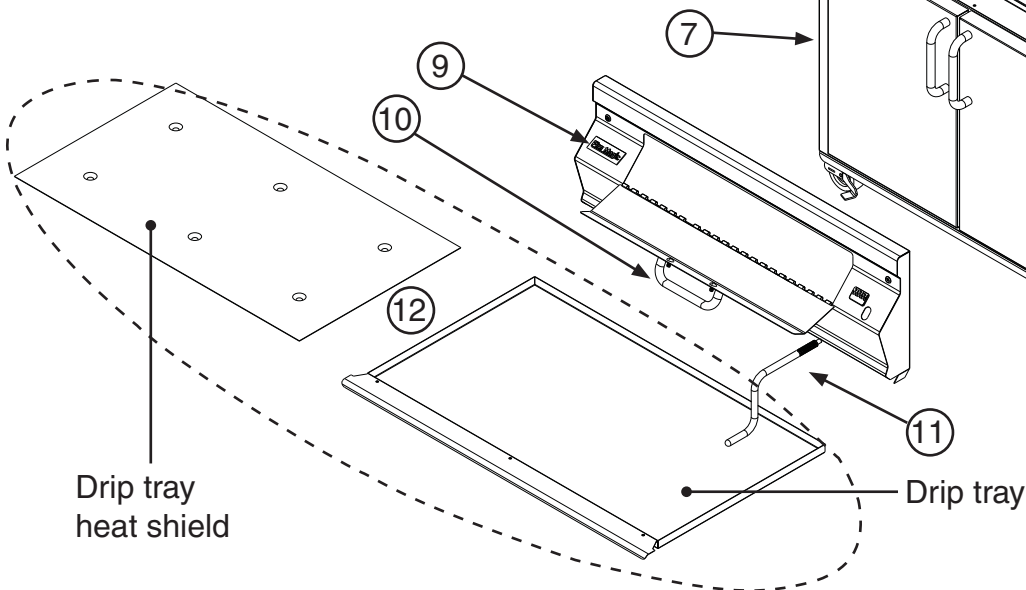

Note: 24" model shown.

## ACCESSORIES

### GRILL BRUSH (optional)

Purchase a Fire Magic® stainless-steel grill brush (sold separately) to keep your grill cleaner. It comes with scraper for large particles and a replaceable head with brass bristles for overall cleaning.



Fig. 7-1

Grill brush with replacement head

### AIR SHUTTERS (Smoker hoods only)

**CAUTION:** The air shutters become very hot when the grill is in use. Use a tool or heat-insulated glove to adjust the air shutters.

The air shutters (Fig. 7-3) on both sides of the smoker oven can be used to regulate the flow of air to the coals when the oven is closed.

### CHARCOAL SHIELD (if equipped)

The charcoal shield allows meat drippings to drip down to the drip tray without affecting the charcoal.

Place it over the coals (and beneath the cooking grids) as shown in Fig. 7-4.

The shield may also be used for smoking or indirect cooking methods. Simply set up as shown (using wood chips if desired), toward one side of the grill. Place the food on the opposite side of the grill.

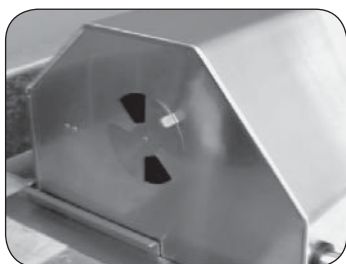

Fig. 7-3

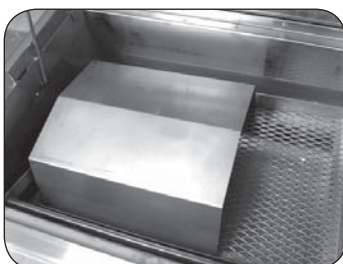

Fig. 7-4

### DRIP TRAY

After each use, wait for the grill to cool and carefully pull out the charcoal drip tray to check it. When nearing full, carefully pull out the drip tray, lifting with both hands to keep the tray level until it is safely discarded.

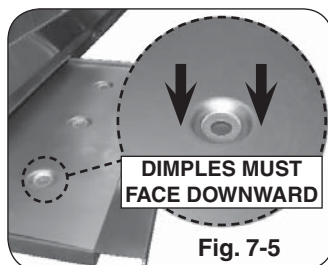

Fig. 7-5

**Note:** The charcoal drip tray has a heatshield to protect from over heating. It may be necessary to remove the heatshield to properly clean out the charcoal drip tray. When reinstalling, the heatshield dimples must face downward as shown in Fig. 7-5.

### WARMING RACK (if equipped)

The warming rack (Fig. 7-2) is packed separately.

To install the warming rack, lift the front of the rack up slightly and insert the rack hangers into the two holes in the back of the inner oven hood. Then lower the front of the rack into a level position to lock the rack in place.

To remove the warming rack, lift up on the front of the rack until the rack hangers pull free from their supporting holes.

**Note:** Removing the warming rack before using the rotisserie will leave more clearance for the meat being cooked. (if applicable)



Fig. 7-2 Warming rack in place inside oven

### USING AND (UN)LOCKING CASTERS (Stand alone only)

The portable cart comes with four (4) casters, two (2) of which are locking and articulated.

For ease in guiding the cart when pushing, steer from behind with the articulated casters and lead with the others.

Before using the grill, always lock the casters by pushing down on the side of the steel rocker labeled **OFF** until the wheel will no longer roll (Fig. 7-6).

Before moving the grill, wait for it to cool, then unlock the wheels again by pressing the side of the steel rocker labeled **ON** until the wheel rolls.



Fig. 7-6  
Locking the casters

## NOTES PAGE

Please use this page to record any information that you may want to have at hand.



## CARE & CLEANING

APPLIANCE MUST BE COMPLETELY COOL WHEN CLEANING. DO NOT SPRAY ANY CLEANER OR LIQUIDS ON THE APPLIANCE WHEN HOT.

The appliance *must* be cleaned as often as once a month (depending on use) to prevent grease build-up and other food deposits.

A clean and well maintained appliance prevents the risk of grease fires.

### COOKING GRIDS

Before and after each use, clean the cooking grids with a Fire Magic Grill Brush (sold separately). Before initial use and periodically, it is suggested that the cooking grids be washed with a mild soap and warm water solution.

### INTERIOR

Empty the charcoal drip tray and screen of all ash and drippings after each use. Clean the charcoal screen, pan, and the interior of the grill with a water and mild soap solution.

The inside of the appliance may be cleaned periodically with oven cleaner if desired. Follow the oven cleaner instructions for proper use.

Be careful not to get oven cleaner on the outside surface of the appliance as it can permanently damage the finish.

### EXTERIOR

Stainless steel surfaces when exposed to temperatures produced by the grilling process will change color. The stainless steel will change color from silver to brown and blue. This can be removed by using stainless steel cleaner.

Clean your appliance by first using stainless steel grill cleaner to remove grease and dirt. Always wipe with the grain (See Fig. 9-1). Next, apply stainless steel polish and wipe down using polish wipes to restore the stainless steel color.

If your appliance is installed in a seaside (salt air) or poolside (chlorine) location, it will be more susceptible to corrosion and must be maintained/cleaned more frequently. Do not store chemicals (such as chlorine or fertilizer) near your stainless steel appliance.

Due to the nature of stainless steel, surface iron oxide deposits may appear. Do not be alarmed – these deposits are removable with stainless steel cleaner through prompt and periodic maintenance. If not attended to promptly, permanent pitting may occur.

By following these recommendations, you will enjoy the beauty and convenience of your appliance for many years to come.

### PROTECTING YOUR APPLIANCE FROM THE WEATHER

An optional cover will protect your appliance when not in use. Allow to cool before covering. Please specify the model number and serial number of your appliance when ordering a cover.



Fig. 9-1 Wipe with grain

# WARRANTY

## PETERSON FIRE MAGIC GRILLS AND ACCESSORIES LIMITED WARRANTY

Robert H. Peterson Co. ("RHP") warrants your Fire Magic® grill to be free from defects in material and workmanship.

Fire Magic® cast stainless-steel burners, stainless-steel cooking grids, and stainless-steel housings are warranted for as long as you own your Fire Magic® grill -- **LIFETIME**. (Except as noted below.)

Fire Magic Choice stainless steel tubular burners are warranted for **TWENTY (20) YEARS**.

Fire Magic® cast brass burners, brass valves, inner liners, manifold assemblies, porcelain housings (including ovens and barbecue faces), and backburner assemblies (except ignition parts) are warranted for **FIFTEEN (15) YEARS**.

Fire Magic® Electric Grills, including stainless steel grid, and housings are warranted for **TEN (10) YEARS**.

Fire Magic® Infra-red burners, flavor grids, Charcoal stainless steel grills, and Smokers are warranted for **FIVE (5) YEARS**; except for the charcoal pan, charcoal grid, wood pellet screen, thermometer, and ash tray; which are warranted for **ONE (1) YEAR**.

Fire Magic® sideburners and all other Fire Magic® grill components (except ignition and electronic parts) are warranted for **THREE (3) YEARS**.

Fire Magic® ignition systems (excluding batteries), electronic components (including lights and thermometers), and grill accessories are warranted for **ONE (1) YEAR**.

### A COPY OF YOUR SALES SLIP FOR PROOF OF PURCHASE IS REQUIRED

This warranty applies to the original purchaser for products which are installed in the United States or Canada and which are operated and maintained as intended for single family residential usage. This warranty is valid only with proof of purchase, shall commence on the date of purchase, and shall terminate (both as to original and any replacement products) on the anniversary date of the original purchase of the product stated on the above schedules.

This warranty covers defects in material and workmanship. This warranty **does not** cover parts which become defective as a result of negligence, misuse, use not in compliance with the Owner's Manual/Installation Instructions, accidental damage, improper handling, improper storage, improper installation, **lack of required routine maintenance** (as specified in the Owner's Manual/Installation Instructions), or electrical damage. Product must be installed as specified in the Owner's Manual/Installation Instructions by a **qualified professional installer**. Modifications to products which are not specifically authorized will void this warranty. Accessories, parts, valves, remotes, etc. when used must be Peterson products or this warranty is void. Warranted items will be repaired or replaced at Peterson's sole discretion. This warranty **does not** apply to rust, corrosion, oxidation, or discoloration unless the affected part becomes inoperable.

This warranty **does not** cover labor or labor related charges, except as provided by separate specific written programs from the Peterson Co. All repair work must be performed by a qualified professional service person and requires prior approval of Peterson.

Peterson may require the defective product or part to be returned to the factory to determine the cause of failure. Peterson will pay freight charges if the product or part is determined to be defective. This warranty does not cover breakage in shipment from our (Independent) distributor to its customer if the damage is determined to have occurred during that shipment.

This warranty specifically excludes liability for **indirect, incidental**, or consequential damages. Some states and provinces do not allow the exclusion or limitation of incidental or consequential damages, so the above exclusion may not apply to you. This warranty gives you specified legal rights, and you may have other rights that vary from state to state or province.

For additional information regarding this warranty, or to place a warranty claim, contact the R. H. Peterson dealer where the product was purchased.

When contacting your Peterson dealer or the R. H. Peterson Co., please provide the following information:

- Your name, address, telephone number, e-mail
- Sales receipt showing where purchased and date purchased
- Model number, serial number of product, date code
- Relevant information: installer, additions, repairs, when defect was first noted

**TO REGISTER YOUR PRODUCT ONLINE GO TO: WWW.RHPETERSON.COM,  
AND CLICK ON PRODUCT REGISTRATION. THANK YOU FOR YOUR PURCHASE.**

<b>Quality Check</b>	<b>Date:</b> _____
<b>Model#:</b> _____	<b>Serial#:</b> _____
<b>Inspector:</b> _____	<b>Workmanship Inspection:</b> _____