

IMPORTANT: You must read the installation and owner's manual provided with the grill.

1-Safety

INSTALLER: Leave these instructions with consumer. **CONSUMER:** Retain for future reference.

CAUTION: WHEN INSTALLING AND OPERATING THIS APPLIANCE, ALL INSTRUCTIONS AND WARNINGS IN YOUR OWNER'S MANUAL MUST BE OBSERVED. FAILURE TO DO SO MAY RESULT IN A FIRE OR EXPLOSION CAUSING PROPERTY DAMAGE, BODILY INJURY, OR DEATH.

This grill must be installed in accordance with local codes and ordinances, or, in the absence of local codes, with either the latest National Fuel Gas Code (ANSI Z223.1/NFPA 54), and Natural Gas and Propane Storage and Handling Installation Code (CSA-B149.1).

This appliance and its individual shutoff valves must be disconnected from the gas-supply piping system when testing the system at pressures in excess of ½ psig. This appliance must be isolated from the gas-supply piping system by closing its dedicated manual shutoff valve during any pressure testing of the gas-supply system at pressures up to and including ½ psig.

This grill is designed for outdoor use only. DO NOT use this grill inside a building, garage, or enclosed area (see paragraph below). DO NOT use this grill in or on a recreational vehicle or boat.

A minimum 5 foot clearance is required between the cooking surface and the overhead construction. When installed under combustible overhead construction, the area above the cooking surface of the grill **must** be covered with an exhaust hood. The exhaust hood provides the protection for the combustible overhead construction. **DO NOT use this appliance under unprotected combustible overhead construction.** When installed under overhead non-combustible construction, an exhaust hood is highly recommended. **When using an exhaust hood:** the area above the cooking surface of the grill must be covered with a hood larger than the cooking area of the grill, and with a minimum of 1200 CFM (cubic feet per minute) for proper outdoor application.

Installation must be performed by a qualified professional service technician.

2-Unpacking

Carefully unpack the grill, removing all packing material and protective film (including the clear film on the drip tray). Verify that all parts have arrived undamaged by consulting the parts list in the owner's manual. Remove foam packed hardware from oven area. (See Fig. 2-1.)

Consult the parts list in the owner's manual. If any parts are missing or damaged, immediately contact the Fire Magic dealer before beginning installation.

Important: The 2 shipping screws must be removed prior to removing the unit from the wooden pallet. The screw located on the bottom left side of the unit is accessed by opening the door. The screw located on the bottom right side of the unit is accessed by removing the lower drawer.

To remove the drawer; pull it completely out. Release the drawer from the drawer slides by pressing the black lever down on the right side, and up on the left side.

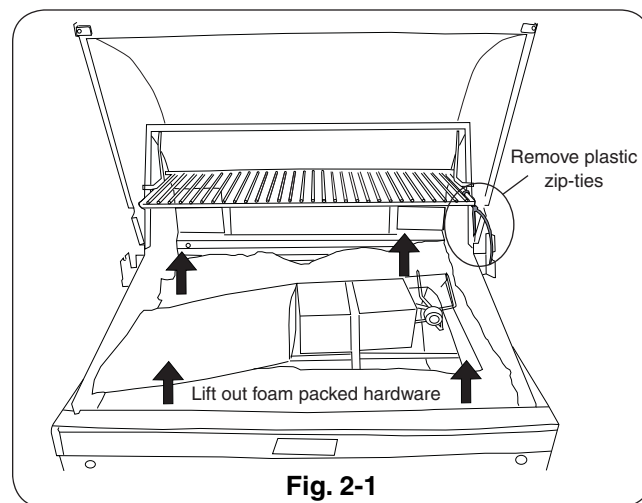

Fig. 2-1

3-Installation

Location

Locate the grill on a flat level surface. Refer to the INSTALLATION REQUIREMENTS section of your grill owner's manual for complete details.

CAUTION: Wind blowing into or across the rear oven lid vent (Fig. 3-1) can cause poor performance and/or dangerous overheating. Orient the grill so that the prevailing wind blows toward the front of the grill (Fig. 3-2).

CAUTION: To prevent dangerous overheating, the rear of the unit must have a minimum clearance of 4" from any non-combustible wall.

INCORRECT

Rear oven lid vent



YOU MUST PROTECT REAR OVEN VENT FROM PREVAILING WIND

Fig. 3-1

CORRECT



PLACE GRILL SO PREVAILING WIND BLOWS TOWARD FRONT OF GRILL

Fig. 3-2

Connect Gas supply

These quick start instructions assume a propane cylinder configured unit. See main instructions for natural gas or household propane configured units.

Place approved propane 20 lb cylinder in tank tray and lock holder in position (Fig. 3-3).

Connect quick coupler hose and regulator supplied with unit to propane cylinder (Fig. 3-4).

Turn all burner control knobs to the **OFF** position. Open the main cylinder valve. Then carefully check all gas connections for leaks with a brush and half-soap/half-water solution before lighting. **NEVER USE A MATCH OR OPEN FLAME TO TEST FOR LEAKS.**

Proper grill airflow must be maintained as shown in Fig. 3-5.

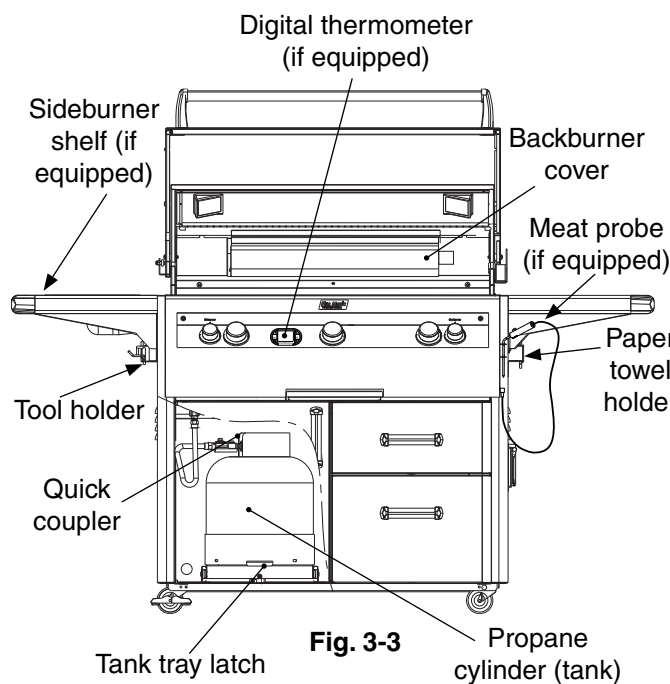

Fig. 3-3

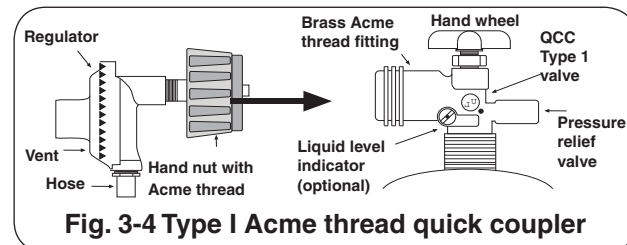
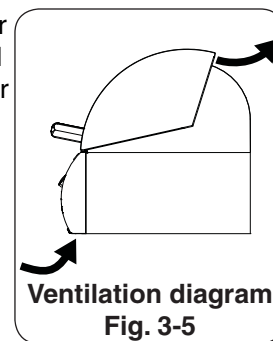

Fig. 3-4 Type I Acme thread quick coupler



Ventilation diagram
Fig. 3-5

To connect the regulator/hose assembly to the propane-gas cylinder valve fitting: Press the hand nut on the regulator over the Acme thread fitting on the cylinder valve. Turn the hand nut clockwise to engage the threads and tighten until snug.

Note: For infrared burner equipped grills; see detailed instructions included in your owner's manual.

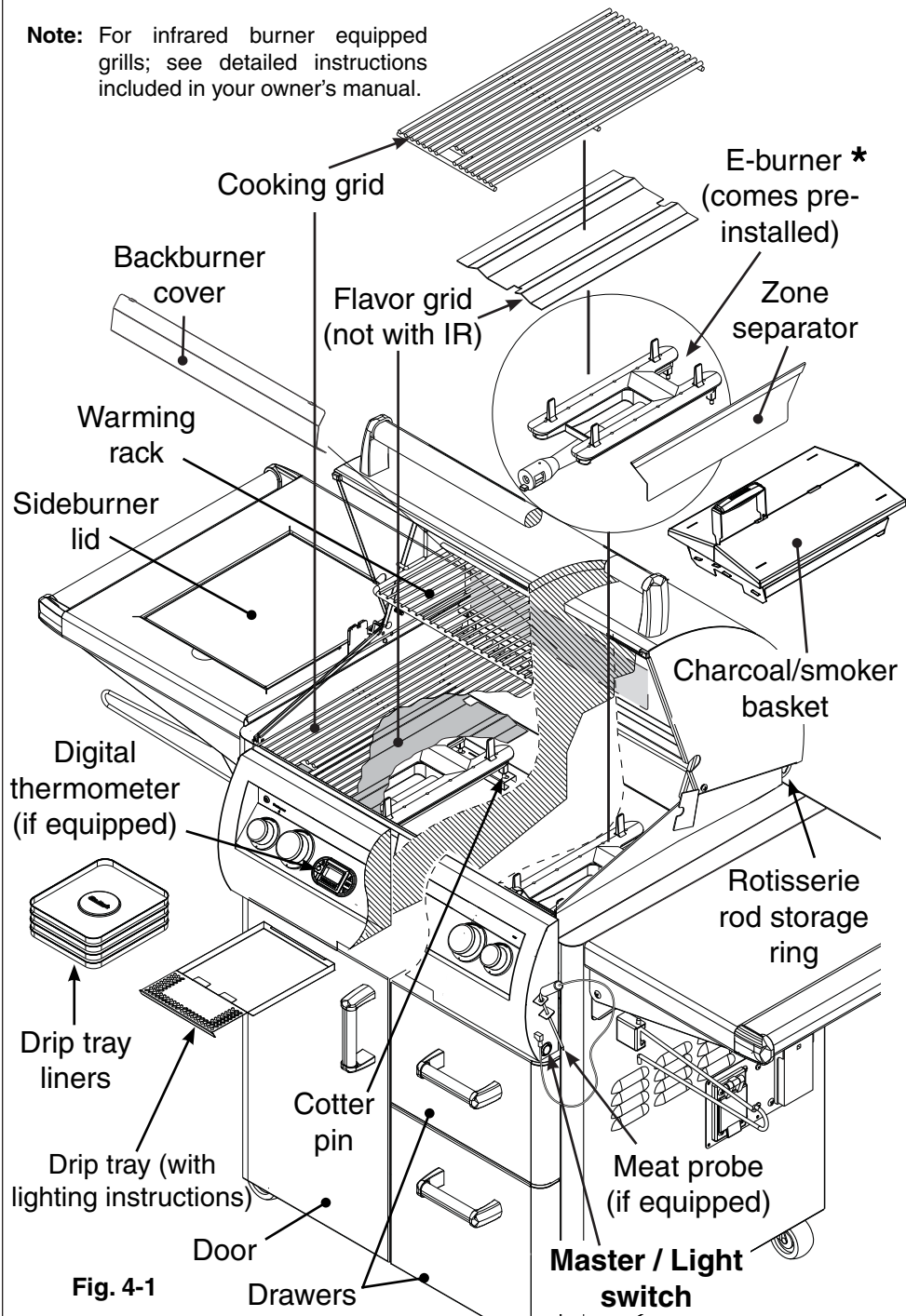

Fig. 4-1

4-Grill Setup

Parts Placement Checklist

Place the following items according to their position and orientation in Fig. 4-1:

Flavor grids, cooking grids, zone separators, backburner cover, warming rack, and meat probe.

Leave pre-installed E-burners in place to maintain proper alignment.

Backburner Cover

Hook the backburner cover over the top of the backburner to protect the backburner from grease, dust and dirt when it is not in use. Remove before use.

Warming Rack

The warming rack comes pre-installed. Remove zip ties before use. Consult the owner's manual to remove or replace.

Charcoal / Smoker Basket (if equipped)

The basket is for use directly above a main burner. Consult the owner's manual for complete installation and operation.

Shelf/Sideburner (if equipped)

Align the four (4) holes in the shelf with the four (4) holes in the side of the cart while aligning and engaging the burner venturi with the orifice (Fig. 4-2). Insert the four (4) screws (provided) into the holes and tighten. Connect the spark wire to igniter electrode (Fig. 4-2). Open sideburner lid, set cap on burner, and set grid into shelf.

*** The burner ports and carry-over slots must be kept clean to ensure proper ignition and operation.**

Replacement parts can be ordered from your local Fire Magic dealer.

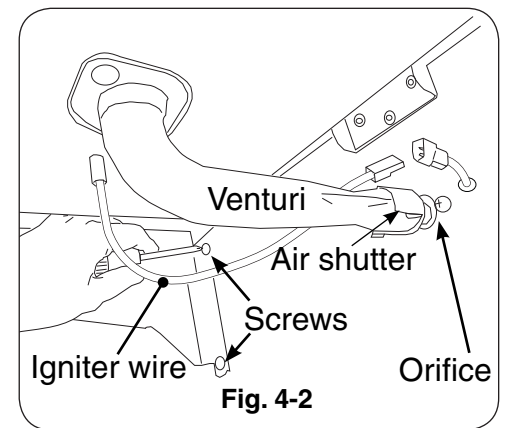

Fig. 4-2

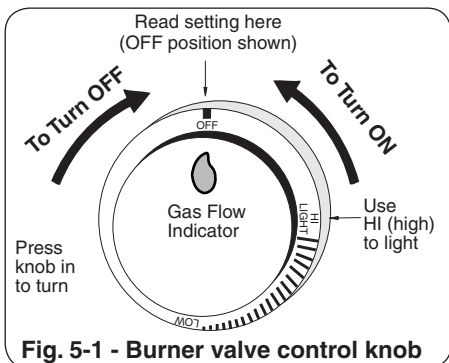

Fig. 5-1 - Burner valve control knob

5-Test

Note: This unit must be connected to 120VAC power for electronic lighting.

1. Open lid(s) or remove cover(s) from burner(s) to be lit.
 2. Turn all gas control knob(s) to their **OFF** position(s).
 3. Turn on the gas at its source and if equipped, press the master switch.
- Note:** **DO NOT** turn on more than one valve at a time for either electronic or manual lighting.
4. Depress the desired control knob **for 5 seconds**, then, while pressing turn it counterclockwise to the **HI LIGHT** position. Once the burner lights, release the knob.

CAUTION:

If a burner does not light within five (5) seconds of turning on the control knob, depress the knob and turn it to the **OFF** position. **WAIT FIVE (5) MINUTES** before repeating step 4. If you smell gas, follow the instructions on the cover of the grill owner's manual. If the burners still do not light after several attempts, refer to the grill owner's manual for manual lighting.

5. Repeat step 4 for each additional burner to be lit.

For your convenience and safety; when the control knob is in the ON position, the gas flow indicator will change from blue to red. (Red indicates gas flow.) See Fig. 5-1.

WHEN OPERATING THIS APPLIANCE WITH PROPANE, ALL INSTRUCTIONS AND WARNINGS MUST BE OBSERVED. FAILURE TO DO SO MAY RESULT IN A FIRE OR EXPLOSION CAUSING SERIOUS INJURY OR DEATH.

‡ MASTERSWITCH (digital thermometer models)

The master switch (Fig. 5-2) controls the power to all lights, igniters, and the thermometer. It allows the power to be turned on or off for safety and convenience. The switch will need to be turned on prior to each grill use, and turned off after each use.

LIGHT SWITCH (analog models)

The light switch (Fig. 5-2) is push button operated, and is located on the right side of the control panel. It controls the power to all lights.

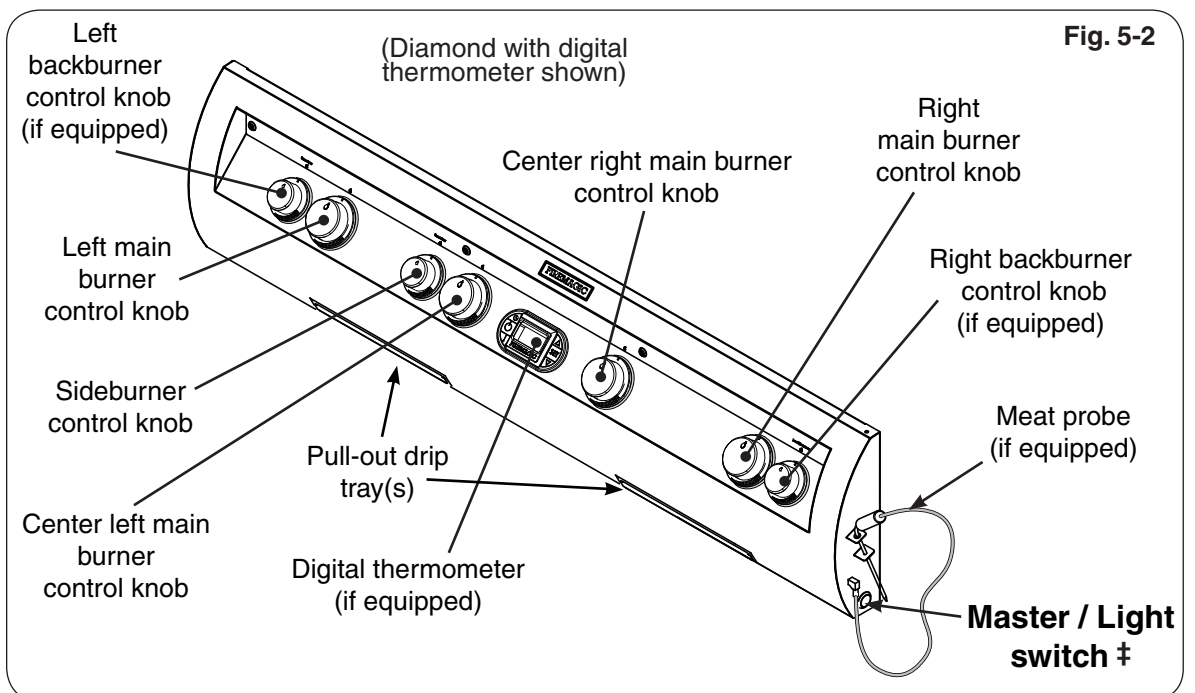

Fig. 5-2

6-Propane Safety

Gas Cylinders

IMPORTANT: READ AND FOLLOW ALL WARNINGS PROVIDED WITH THE PROPANE-GAS CYLINDER.

READ ALL SAFETY INSTRUCTIONS AND WARNINGS REGARDING THE USE OF PROPANE GAS FOUND IN YOUR OWNER'S MANUAL.