



Standard Burner Systems:

- G4-2-12(P)
- G4-2-16/19(P)
- G4-2-18/20(P)
- G4-2-24(P)
- G4-2-30(P)
- G4-2-36(P)
- G4-2-42(P)
- G4-2-48(P)
- G4-2-60(P)



**FOR INSTALLATION IN
SOLID-FUEL BURNING
FIREPLACES**

G4/GX4-2 SEE-THRU

⚠ WARNING

If the information in this manual is not followed exactly, a fire or explosion may result, causing property damage, personal injury, or loss of life.

- Do not store or use gasoline or other flammable vapors and liquids in the vicinity of this or any other appliance.

WHAT TO DO IF YOU SMELL GAS:

- Open a window.
- Do not try to light any appliance.
- Do not touch any electrical switch; do not use any phone in the building.
- Immediately call the gas supplier from neighbor's phone. Follow the gas supplier's instructions.
- If you cannot reach the gas supplier, call the fire department.

Installation and service must be performed by an NFI Certified or other qualified professional installer, service agency, or the gas supplier.



We recommend that our gas hearth products be installed and serviced by professionals who are certified in the U.S. by the National Fireplace Institute® (NFI) as NFI Gas Specialists.

Important: Read these instructions carefully before starting installation of the gas log set.

This Real Fyre gas log set is to be installed only in a solid-fuel-burning fireplace with a working flue and constructed of noncombustible material. Solid fuels shall not be burned in a fireplace where this gas log set is installed. The installation, including provisions for combustion, ventilation air, and required minimum permanent vent opening, must conform with the National Fuel Gas Code and applicable local building codes. A damper stop clamp is included to maintain the minimum permanent vent opening and to prevent full closure of the damper blade. **The chimney damper should be fully opened when burning the log set.**

Important: To comply with certification, listings, and building code acceptance, and for safe operation and proper performance, ONLY Peterson parts and accessories may be used with this gas log set.

INSTALLER & CONSUMER
These instructions **MUST** be retained with this appliance.



Listing No. 1188

TABLE OF CONTENTS

3	IMPORTANT INFORMATION
4	PARTS LIST
5	HOW TO INSTALL THE G4 SEE-THRU GAS LOG SET
5	BURNER CONNECTION INSTALLATION
5	BURNER PLACEMENT
5	CONNECTING THE GAS SUPPLY
6	HOW TO INSTALL THE REAL FYRE GAS LOG SET
6	SAND/VERMICULITE PLACEMENT
6	GLOWING EMBER & GRATE PLACEMENT
6	LOG PLACEMENT
6	DAMPER CLAMP
7	LOG PLACEMENT SUGGESTIONS
9	LIGHTING INSTRUCTIONS
10	MAINTENANCE AND SERVICE
10	MAINTENANCE
10	SERVICE
10	FLAME DESCRIPTION
10	TROUBLESHOOTING THE GAS LOG SET
12	OPTIONAL CONTROLS FOR YOUR REAL FYRE BURNER SYSTEM
13	NOTES PAGE
14	WARRANTY

IMPORTANT INFORMATION

Check to be sure the gas log set is designed for the proper gas type. Real Fyre log sets are designed for use with natural gas unless clearly labeled for propane gas. Sets designed for use with propane gas must be installed with a safety pilot system. Never use propane gas in a log set designed for natural gas or natural gas in a log set designed for use with propane gas.

The installation, including provisions for combustion and ventilation air, must conform with local codes, or in the absence of local codes, with the *National Fuel Gas Code, ANSI Z223. 1 and NFPA54.*

The appliance and its individual shutoff valve must be disconnected from the gas-supply piping system when testing the system at test pressures in excess of ½ psig. This is accomplished by closing the gas-supply line valve, as required by NFPA54.

The appliance must be isolated from the gas-supply piping system by closing its individual manual shutoff valve during any pressure testing of the gas-supply system at test pressures equal to or less than ½ psig.

The minimum inlet gas-supply pressure for the purpose of input adjustment is 7" water column (w.c.) for natural gas and 11" w.c. for propane gas.

The maximum inlet gas-supply pressure for this burner is 10½" w.c. for natural gas and 13" w.c. for propane gas. A fireplace screen must be in place when the log set is burning.

CAUTION: Where fitted, operate the log set with the fireplace doors fully open.

The recommended firebox dimensions in which the G4-2 burner is to be installed are listed in the table below:

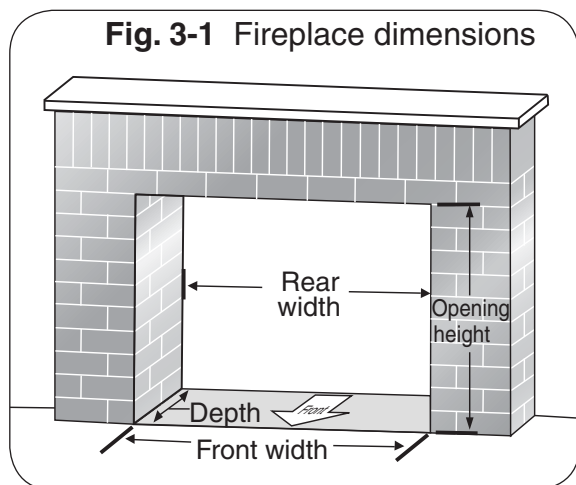

Note: Front and rear width are assumed the same for see-through fireplaces.

Log Set Size	Minimum Fireplace Dimensions				BTU (natural)	BTU (propane)
	Depth	Height	Width †	Min. vent opening sq. in. *		
12"	15"	18"	18"	25	40k	30k
16/19"	16"	18"	25"	29	50k	45k
18/20"	18"	18"	26"	51	75k	50k
24"	18"	18"	30"	57	90k	65k
30"	18"	18"	36"	57	90k	65k
[36"]	20"	18"	42"	82	130k	100k
[42"]	20"	18"	48"	94	150k	120k
[48"]	20"	18"	54"	107	170k	130k
[60"]	20"	18"	66"	120	190k	140k

† This required width allows for centering of the log set. Add 4" to front width if the burner is to be installed with a pilot kit.

* The chimney vent opening provided is based upon a required minimum chimney height of 15 feet.

Note: Bracketed log sets exceed the 90,000-BTU maximum input allowed by the LA Standard and are not included in the RADCO listing.

Minimum Free Opening Area of Chimney Damper for Venting (sq. in.)									
For Factory-Built Fireplaces *									
Chimney Height	12"	16/19"	18/20"	24"	30"	36"	42"	48"	60"
15' (min.)	18	22	36	46	46	66	76	86	96
20'	15	19	29	38	38	58	68	78	88
30'	12	15	23	29	29	49	59	69	79

* For Masonry-Built Fireplaces; add 10 sq. in. to amount shown.

PARTS LIST

Note: The parts for the Woodland Oak 24" set (WOG4-2-24) are illustrated and listed. Log styles and part sizes will vary depending on the log set ordered. When ordering replacement parts, be sure to indicate your log set model. (See items in bold below.)

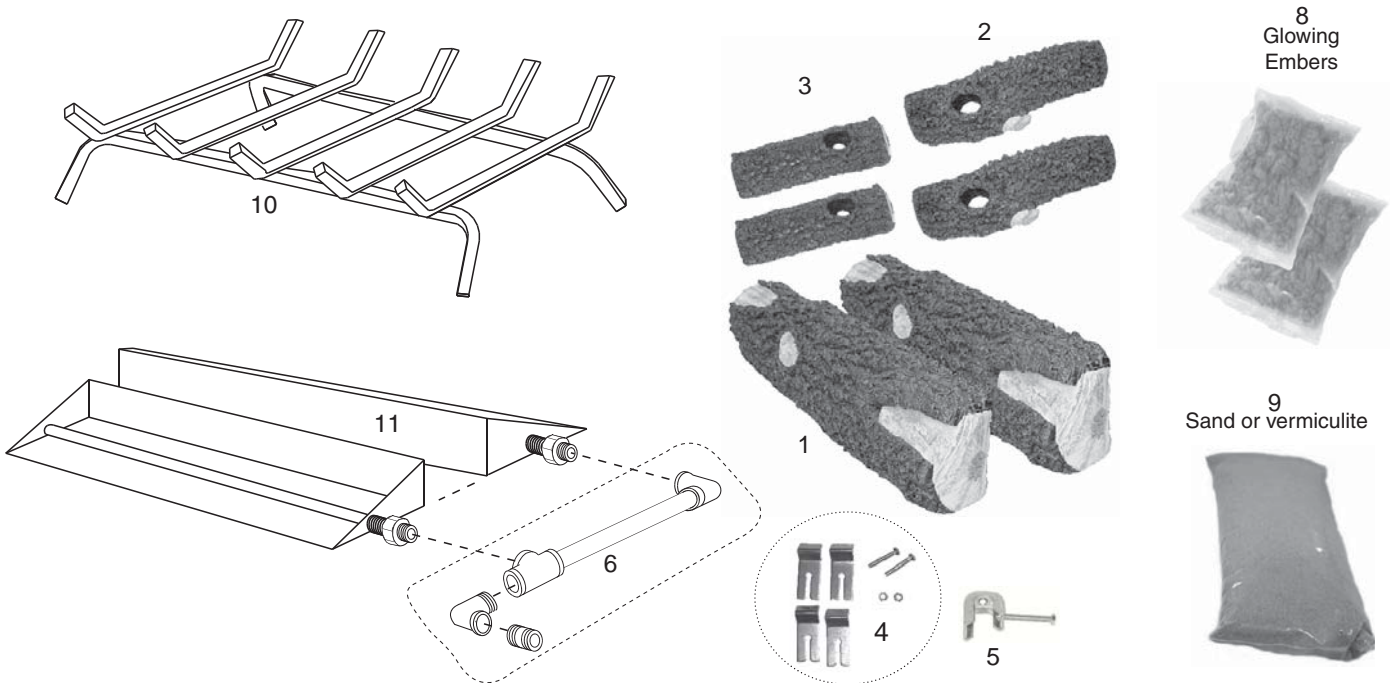

Note: 24" Woodland Oak log set depicted here as an example.

Item No.	Part No.	Description
1.	WOL-24B	Woodland Oak bottom 11" (2)
2.	WOL-15T	Woodland Oak top log 15" (2)
3.	WOL-9T	Woodland Oak top log 9" (2)
4.	400768	Stabilizer clips with screws and nuts (replacement package also includes a damper clamp)
5.	DC-1	Damper clamp
6.	TEA-1	Joint assembly
7.	CK-14-12	Connector kit (with adapters)
8.	EM-1	Glowing Embers (2)
9.	CS-12 or LF-15	Sand (2) (natural) Vermiculite (2) (propane)
10.	SD2-24 or SX2-24	Fireplace grate G4 Fireplace grate GX4
11.	GG-24	Burner pan assembly (2)*

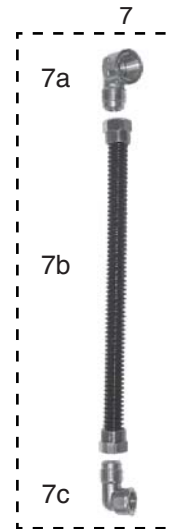

*For propane units, add a "P" to the end of the part number.

Note: Values in **bold** change with burner size, model and log set.

Replacement parts can be ordered from your local Real Fyre dealer.

HOW TO INSTALL THE G4 SEE-THRU GAS LOG SET

Important: To comply with certification, listings, and building code acceptances, and for safe operation and proper performance of this log set, use ONLY Peterson Real Fyre parts and accessories. Use of other controls, parts, and accessories that are not approved for use with Real Fyre gas log sets is prohibited and will void all warranties, certifications, listings, and building code approvals, and may cause property damage, personal injury, or loss of life.

Note: This gas log set must be installed by an NFI Certified or other qualified professional installer. Instructions must be followed carefully when installing to ensure proper performance and full benefit from the gas log set.

BURNER CONNECTION INSTALLATION

Check the PARTS LIST to be sure all parts are included with the connection. Pipe compound resistant to the action of propane gas must be used on all threaded male connections, except brass to brass.

Refer to the PARTS LIST when completing the following instructions.

1. Connect the $\frac{3}{8}$ " x 6" pipe to the $\frac{3}{8}$ " elbow. Continue to connect the 6" nipple to the $\frac{3}{8}$ " tee.
2. Connect the $\frac{3}{8}$ " street elbow to the tee and connect the $\frac{3}{8}$ " x 1" nipple.
3. Once the fittings are assembled, continue to connect the burner and fuel injector assembly (Item #11) to the tee and elbow.

Rotate each burner pan to tighten the complete assembly together. Ensure that all connections are tight.

There should be an approximately 2" gap between the burner pans after the connector kit has been installed (Fig. 5-1). Once the assembly is completed, the burner pan will look like Fig.5-2.

BURNER PLACEMENT

Make sure the gas to the fireplace is off. Be sure that the fireplace floor is clear of any debris. Center the burner assembly in the fireplace and check to see if it lies lay flat on the floor. Place the grate squarely over the burner pans and install the stabilizer clips (Item #4) to the grate bars so that the slots of the stabilizer clips fit over the back edge of the burner pans (see Fig. 5-1). Use the nuts and bolts provided to secure the clips in place. Remove the grate to continue installation.

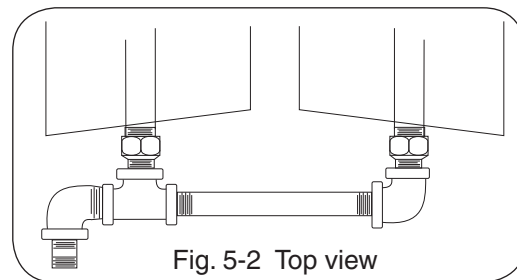
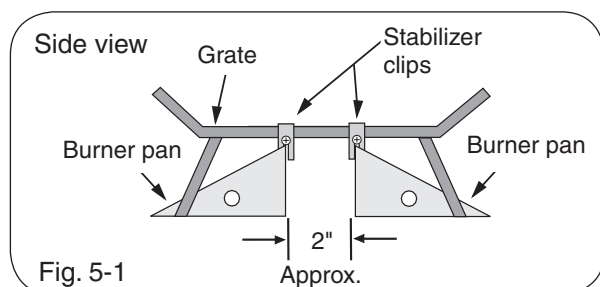

CONNECTING THE GAS SUPPLY

Note: DO NOT run the gas line between the two burners. Running the gas line between the burners may cause overheating of the gas line and control valve (if equipped).

If your burner is to be installed with a pilot kit; carefully follow the instructions supplied with your pilot kit for specific gas connection.

1. Attach the small adapter (Item 7C) to the nipple, using a pipe compound resistant to all gases. Tighten securely. **DO NOT REMOVE THE FUEL INJECTOR / AIR MIXER.** Then attach one end of the flex connector (Item 7B) to the small adapter. Tighten securely.
2. **Be sure gas to the fireplace is off.** Attach the large adapter (Item 7A) to the gas-supply stub using a pipe compound resistant to all gases. Tighten securely. Then attach the open end of the flex connector to the large adapter. Tighten securely. Ensure the pans rests level on the fireplace floor after connection. Adjust the pans if necessary.
3. Use a long-necked butane lighter, or lay a lighted match next to the burner pipe, and carefully turn on the gas supply until the burner ignites. Test at all connections for leaks using the appropriate soapy water solution. If bubbles appear, a leak is present. Turn off the gas and tighten at all connections. Repeat until no leaks are present. If a leak persists, turn off the gas supply and contact the local gas company or dealer. **NEVER USE A FLAME TO CHECK FOR LEAKS.**

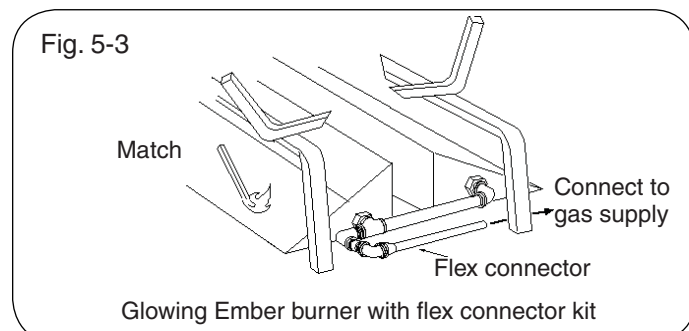

HOW TO INSTALL THE REAL FYRE GAS LOG SET

IMPORTANT

For all valves, the air **MUST** be purged from the gas line before the pilot will light properly. The time taken to do this will depend on the length of gas line from the meter to the unit and the length of time since the unit or gas line was last used (in the case of non-use during warm weather, for example). It may take from 3-15 minutes before all the air is purged and the pilot will light properly. This is done using the method for lighting the pilot, but holding in the control valve for a longer period. Follow the lighting instructions in this manual for the specific valve type.

Sand/vermiculite is available for the Real Fyre burner pan. **Sand** is used with natural gas, and **vermiculite** is used with propane gas. **Never use sand in a burner designated for use with propane gas.**

The sand (Item #9) is composed of fine-quality sterile sand that has been carefully sized for even flame distribution. It is free from foreign elements that could cause unpleasant odors and flame distortion. It provides quiet operation, eliminating the "hiss" sound heard with other materials.

The vermiculite is specially selected for use with propane gas. It maximizes flame distribution and reduces carbon buildup.

SAND/VERMICULITE PLACEMENT

With the burner off and in place, fill the burner pans completely with sand/vermiculite. Slope sand/vermiculite at the same angle as the burner pan. This is important to ensure smooth, quiet distribution. Pour a small amount of sand/vermiculite along the side edges and back of the burner pans where they touch the floor (Fig. 6-1). This will ensure against flame diversion.

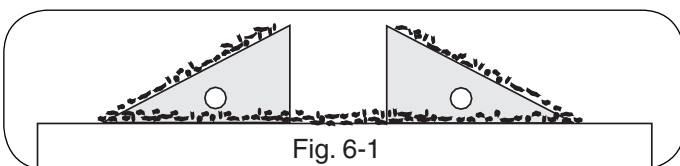

GLOWING EMBER & GRATE PLACEMENT

Sprinkle the glowing embers (Item #8) lightly and evenly over the entire surface of the sand/vermiculite, making sure that the pilot is not covered. Center the grate over the burners so that the stabilizer clips slide over the back edges of the pans (see Fig. 6-2).

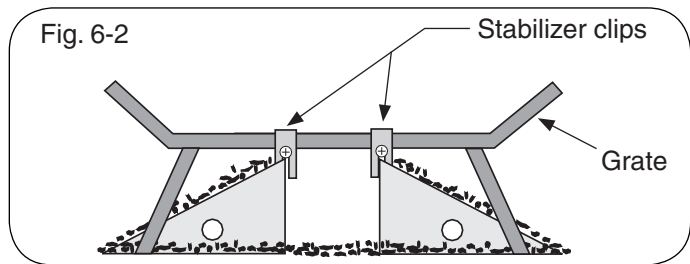

LOG PLACEMENT

For best performance and operation, log placement is very important. Logs are placed on the grate with the flat side inward and the rounded front side against the front of the grate (Fig. 6-3). The space between the

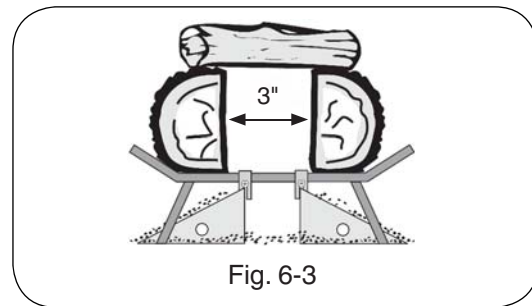

logs will be a nominal 3".

Top logs should be placed diagonally across the bottom logs with space between the logs so the flame is not choked off. (See p. 6-7 for suggested log placements.)

The top logs can be moved to achieve the desired flame patterns. The smaller logs are leaned against the top logs.

DAMPER CLAMP

The damper clamp with hex bolt (Fig. 6-4) is provided as a means to prevent full closure of the damper blade. The clamp is easily attached to most damper blades with pliers or a wrench, and must be permanently installed. The clamp is designed to prevent accidental closure of the damper when installed as illustrated (Fig. 6-5 and Fig. 6-6). Should the clamp not fit, or fail to provide the permanent vent opening listed in the table found on the previous page, have a permanent stop installed, remove the damper blade, or have the damper cut to provide the minimum permanent opening required.

Note: These are minimum damper opening specifications. The damper must be completely opened when operating this gas appliance to achieve the best ventilation possible.

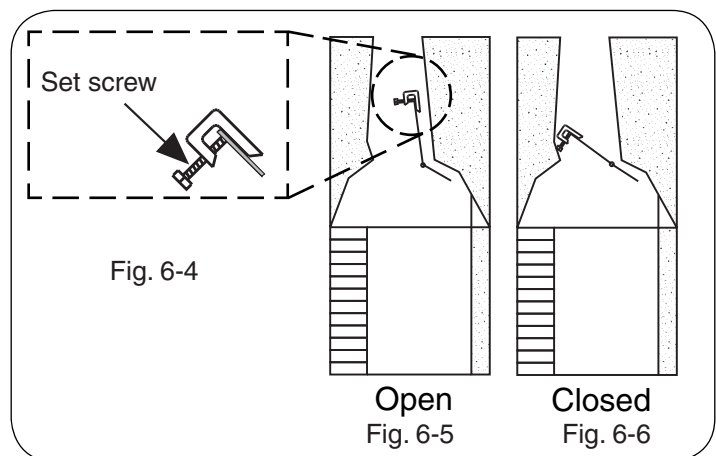

LOG PLACEMENT SUGGESTIONS

The vented gas logs can be placed in any number of different desired arrangements. On the next two pages, some suggested placements are shown. Regardless of which arrangement you choose, allow adequate spacing of the logs for a clean burn and to limit flame impingement on the logs.

CAUTION: BURN HAZARD! LOGS WILL REMAIN HOT FOR SOME TIME AFTER USE.

You must maintain the log layout as shown to ensure proper operation of the log set. If you need to reposition any log to maintain the proper layout, use heat-resistant gloves or allow logs adequate time to cool before handling.

View from above

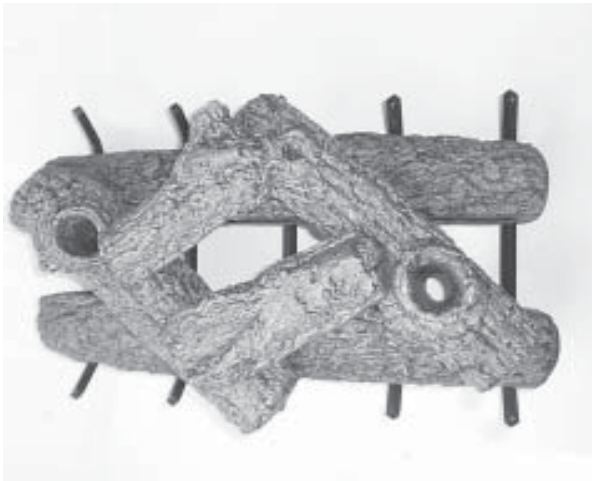

RG4-2-24
Golden Oak

View from face

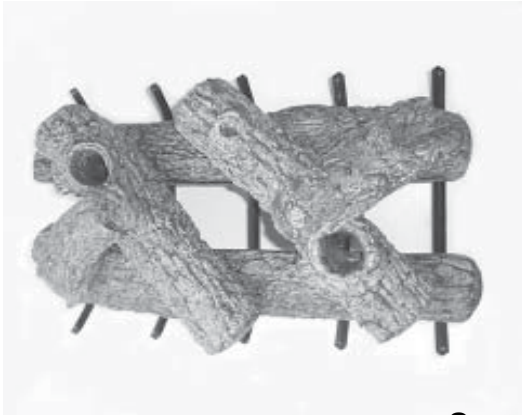

Fig. 7-2

Suggested layout No. 1

LOG PLACEMENT SUGGESTIONS (Cont.)

View from above



**RG4-2-24
Golden Oak**

View from face



Fig. 8-1

Suggested layout No. 2

View from above



**SG4-2-24
Split Oak**

View from face



Fig. 8-2

Suggested layout No. 3

View from above

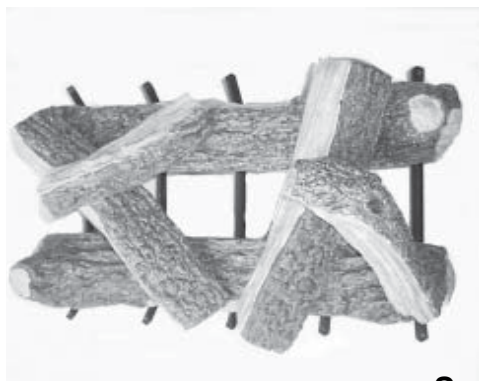

**SG4-2-24
Split Oak**

View from face



Fig. 8-3

Suggested layout No. 4

LIGHTING INSTRUCTIONS

Before operating your gas log set:

1. Be sure your fireplace is free from flammable liquids or combustible materials.
2. Be sure your damper is open.
3. Smell all around the gas log set for the odor of escaping gas. **IF YOU SMELL GAS, FOLLOW THE INSTRUCTIONS ON P. 1.**

If your gas log set is operated by the fireplace valve:

1. Lay a lighted long-stem match on the surface of the embers near the gas inlet (**do not hold the match in your hand**) or use a lighted long-necked butane lighter (Fig. 9-1).
2. Slowly turn the fireplace remote valve to the **ON** position. Your log set should light.
3. If the log set does not light before the match goes out, immediately turn the valve to the **OFF** position.
4. Wait approximately five (5) minutes to clear out any gas, and repeat steps 1-3 above.
5. If your log set fails to light again, turn the valve to the **OFF** position and contact your dealer or gas supplier.
6. **To extinguish your gas log set**, turn the valve to the **OFF** position. Be sure the valve is turned fully off to avoid any gas leakage.

If your burner is operated by a pilot kit:

1. Carefully follow the lighting instructions supplied with your pilot kit for the steps to ignite the burner.

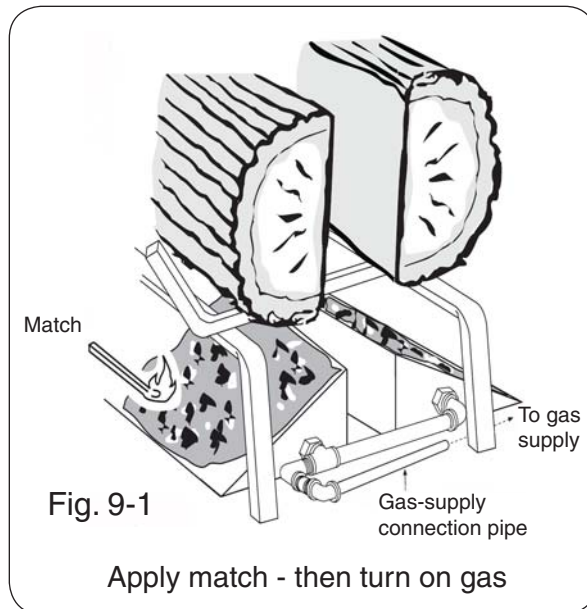

MAINTENANCE AND SERVICE

MAINTENANCE

Once installed and operating properly, the Real Fyre gas log set requires very little maintenance. You should inspect the log set and control annually for the following:

1. **Excessive Sooting** - Some sooting of the log set is normal and adds to the appearance of burned wood. If sooting accumulates, you may brush the soot off with a stiff brush. Do not use water or soot cleaners to clean off the soot.
2. **Settling of glowing embers and sand/vermiculite** - Moisture may cause the sand/vermiculite and glowing embers in the burner pan to settle and affect the burn. Using a screwdriver or flat-blade knife, you can carefully stir the sand/vermiculite and embers, loosening the materials.
3. **Debris around the control** - Inspect the control and pilot to be sure it is free of any dirt or debris.

4. **Insects and burner blockage** - Check the burner ports and the air mixer, if present, to make sure they are free from debris. Blocked burner ports and orifices may result in poor flame distribution or flame at air mixer (if equipped). Reference SOLUTION, to symptoms 2-4, of TROUBLESHOOTING.

SERVICE

While some minor service conditions may be handled by the owner of the log set, it is recommended that a qualified professional service technician be called to service the gas log set and control should service be required. The TROUBLESHOOTING section of these instructions serves as a guide for ensuring optimum performance of the gas log set.

FLAME DESCRIPTION

Observe the flames. The flames should be blue at the base and a combination of blue/yellow at the body and tips. The flames should be 17" to 19" tall from the fireplace floor.

TROUBLESHOOTING THE GAS LOG SET

SYMPTOM	CAUSE	SOLUTION
1. Excessive smoking and sooting Note: Like burning natural firewood, the Real Fyre gas log set is designed to burn with a yellow, smoky flame. Some sooting is common and desirable.	A. Poor draft or downdraft	A. Check for chimney blockage. Be sure chimney is at least 3' taller than anything within 10' of it in all directions. If not, consult a chimney sweep. Chimney cap or fan may help. Under severe conditions, you may need to open a window near the fireplace about 1" to 2" when burning the log set.
	B. Improper set for gas used	B. Use only a natural-gas set with natural gas. Use only a propane-gas set with propane gas.
	C. Damper closed	C. Open damper fully when operating the gas log set.
	D. Set is positioned too close to the front of the firebox	D. Move set so that the back of the grate touches the back wall of the firebox.
	E. Improper log placement	E. Be sure the bottom logs are spaced at least 3" apart. Top logs should be placed to minimize flame impingement.
	F. Minimum ventilation not met	F. Remove the log set. Inadequate fireplace ventilation.
	G. Air mixer on propane set is closed	G. Open air mixer completely

TROUBLESHOOTING THE GAS LOG SET (Cont.)

SYMPTOM	CAUSE	SOLUTION
2. Low flame	A. Incorrect log set for type of gas used	A. Consult the dealer for proper set.
	B. Insufficient gas supply	B. Other gas appliances may be competing for gas supply. Consult installer or plumber. Orifice size is based upon 7" w.c. pressure for natural gas and 11" w.c. pressure for propane gas. Plumbing must supply adequate pressure.
	C. Blockage or kink in connector kit, plumbing, or burner orifice	C. Clean out blockage. If connector kit is kinked, replace it.
	D. Valve not fully open	D. Open valve fully.
3. Uneven flame distribution (Lower at one end of the burner)	A. Clogged or blocked port holes	A. Portholes can be cleared of foreign object by running a wire through them.
	B. Insufficient gas pressure and/or supply	B. Consult installer or plumber. (See solution 2b)
	C. Sand/vermiculite may be packed down too tightly or not evenly	C. Loosen sand/vermiculite around burner pipe by running a kitchen knife along both sides of pipe. Even out sand/vermiculite in burner pan.
	D. Auxiliary shutoff valve partially closed	D. Open valve fully. Usually you will find this along the wall 3' from the fireplace.
	E. Valve not fully open	E. Open valve fully.
4. Flame backing out of air mixer	A. Clogged or blocked portholes	A. Portholes can be cleared of foreign object by running a wire through them.
	B. Insufficient gas pressure and/or supply	B. Consult installer or plumber. (See solution 2b).
	C. Vermiculite may be packed down too tightly	C. Loosen vermiculite around the burner by running a kitchen knife along both sides of the pipe. Be sure vermiculite (not sand) is used with an air mixer.
	D. Excessive gas pressure	D. Contact the gas supplier.

OPTIONAL CONTROLS FOR YOUR REAL FYRE BURNER SYSTEM

This unit may come without a valve installed.

It may be connected directly to and operated by your fireplace valve.

Alternatively, your Real Fyre burner may be operated using a number of optional Peterson control systems (listed below). Peterson control systems are engineered to provide convenient, safe, and reliable operation of your gas burner system.

For safe operation, proper performance, and to comply with safety standards and certifications, use only Robert H. Peterson Company control systems, parts, and accessories with your Real Fyre burner system.

If you have purchased a valve separately, follow the installation instructions that come with your control system.

Peterson Control System and Combinations

Primary Control Method	Order #	
Manual On/Off Systems		
Manual on/off knob (match lit, no pilot)	AV-17	
Manual on/off rod handle (match lit, no pilot)	AV-18	
Manual Safety Pilot Systems*		
Safety pilot w/knob	SPK-20	
Safety pilot w/rod handle	SPK-21	
Low-profile valve	SPK-26	
Piezo spark pilot ignition	SPK-32	
Piezo intermittent ignition pilot	SPK-33	
Remote Safety Pilot Systems*		
Toggle switch	N/A	And also requires one of: APK-11(M)(P) or APK-10(M)(P) or EPK-01
Wall switch	WS-1	
Wall timer	WS-2	
Wood chip switch	WCS-1	
RUS remote	RUS-1	
Remote	RR-1	
Deluxe remote	RR-2	
Pine cone remote receiver	PC-105	
RVF remote	RVF-1	
Wall switch (variable w/switch)	WS-3	
Variable flame-height remote	VR-1A	APK-15(P) or APK-17(P)
Deluxe variable flame-height remote	VR-2A	

*When systems are to be used with propane gas, add a "P" to the control model no. (e.g., APK11MP). Propane burner sets require a safety pilot system. Not all safety pilot systems are available for all burner set sizes.

***M" stands for remote-capable systems. (Remote not included.)

Please use this page to record any information that you may want to have at hand.

WARRANTY

PETERSON VENTED DECORATIVE GAS APPLIANCE LIMITED WARRANTY

Robert H. Peterson Co. ("RHP") warrants your Real Fyre® vented decorative gas appliance to be free from defects in material and workmanship.

Peterson vented ceramic refractory gas logs are warranted for **as long as you own them (lifetime)**.

Peterson vented burner assemblies are **WARRANTED for TEN (10) YEARS**. Peterson vented outdoor stainless-steel burner assemblies are warranted for **FIVE (5) YEARS**.

Peterson glass, gems, nuggets, and fiber-ceramic blend gas logs are warranted for **FIVE (5) YEARS**.

SPK-26 controls are warranted for **THREE (3) YEARS**.

APK-17 controls (including -17 valve) are warranted for **TWO (2) YEARS**.

All other Peterson valves, pilots, and controls are warranted for **ONE (1) YEAR (excluding batteries)**.

A COPY OF YOUR SALES SLIP FOR PROOF OF PURCHASE IS REQUIRED

This warranty applies to the original purchaser for products which are installed in the United States or Canada and which are operated and maintained as intended for single family residential usage. This warranty is valid only with proof of purchase, shall commence on the date of purchase, and shall terminate (both as to original and any replacement products) on the anniversary date of the original purchase of the product stated on the above schedules.

This warranty covers defects in material and workmanship. This warranty **does not** cover parts which become defective as a result of negligence, misuse, use not in compliance with the Owner's Manual/Installation Instructions, accidental damage, improper handling, improper storage, improper installation, **lack of required routine maintenance** (as specified in the Owner's Manual/Installation Instructions), electrical damage, local gas impurities or failure to protect against combustibles. Product must be installed (and gas must be connected) as specified in the Owner's Manual/Installation Instructions by a **qualified professional installer**. Modifications to products which are not specifically authorized will void this warranty. Accessories, parts, valves, remotes, etc. when used must be Peterson products or this warranty is void. Warranted items will be repaired or replaced at Peterson's sole discretion. This warranty **does not** apply to rust, corrosion, oxidation, or discoloration unless the affected part becomes inoperable.

This warranty **does not** cover labor or labor related charges, except as provided by separate specific written programs from the Peterson Co. All repair work must be performed by a qualified professional service person and requires prior approval of Peterson.

Peterson may require the defective product or part to be returned to the factory to determine the cause of failure. Peterson will pay freight charges if the product or part is determined to be defective. This warranty does not cover breakage in shipment from our (Independent) distributor to its customer if the damage is determined to have occurred during that shipment.

This warranty specifically excludes liability for **indirect, incidental**, or consequential damages. Some states and provinces do not allow the exclusion or limitation of incidental or consequential damages, so the above exclusion may not apply to you. This warranty gives you specified legal rights, and you may have other rights that vary from state to state or province.

For additional information regarding this warranty, or to place a warranty claim, contact the R. H. Peterson dealer where the product was purchased.

When contacting your Peterson dealer or the R. H. Peterson Co., please provide the following information:

- Your name, address, telephone number, e-mail
- Sales receipt showing where purchased and date purchased
- Model number, serial number of product, date code
- Relevant information: installer, additions, repairs, when defect was first noted

**TO REGISTER YOUR PRODUCT ONLINE GO TO: WWW.RHPETERSON.COM,
AND CLICK ON PRODUCT REGISTRATION. THANK YOU FOR YOUR PURCHASE.**