

Burner Systems:

- GF-16/18-11(P)
- GF-24-11(P)
- GF-30-11(P)

Log Sets:

- Charred Aged Split Oak
 CHAS-(16/18, 24, 30)
- Charred Frontier Oak
 CHFR-(16/18, 24, 30)



In fireplaces with glass doors, this log set may be used with the glass doors open **or closed**.

**FOR INSTALLATION IN
 SOLID-FUEL BURNING
 FIREPLACES***

**DESIGN CERTIFIED
 to
 Vented Decorative Appliance
 ANSI Z21.60b-2004
 CSA 2.26b-2004**

GF SERIES BURNER

WARNING

If the information in this manual is not followed exactly, a fire or explosion may result, causing property damage, personal injury, or loss of life.

Do not store or use gasoline or other flammable vapors and liquids in the vicinity of this or any other appliance.

WHAT TO DO IF YOU SMELL GAS:

- **Open a window.**
- **Do not try to light any appliance.**
- **Do not touch any electrical switch; do not use any phone in the building.**
- **Immediately call the gas supplier from a neighbor's phone. Follow gas supplier's instructions.**
- **If you cannot reach the gas supplier, call the fire department.**

Installation and service must be performed by a qualified professional installer, service agency, or the gas supplier.

This appliance is only for use with the type of gas indicated on the rating plate.

IMPORTANT: READ THESE INSTRUCTIONS CAREFULLY BEFORE STARTING INSTALLATION OF THE UNIT.

The Real-Fyre burner system is to be installed only in a solid-fuel burning fireplace with a working flue and constructed of noncombustible material. The installation, including provisions for combustion and ventilation air must conform with the *National Fuel Gas Code, ANSI Z223.1/NFPA 54*, or the *CSA B149.1, Natural Gas and Propane Installation Code*, and applicable local building codes.

A damper clamp is included to maintain the minimum permanent vent opening and to prevent full closure of the damper blade. **The chimney damper MUST be fully opened when burning the unit. The unit is designed to burn with yellow flames; thus adequate ventilation is absolutely necessary.**

To comply with certification, listings, and building code acceptances, and for safe operation and proper performance of this burner system, use ONLY Peterson parts and accessories. Use of other controls, parts, and accessories that are not designed for use with Real-Fyre burner systems is prohibited and will void all warranties, certifications, listings, and building code approvals, and may cause property damage, personal injury, or loss of life.

***Note:** Solid-fuels shall not be burned in a fireplace where a decorative appliance is installed.



We recommend that our gas hearth products be installed and serviced by professionals who are certified in the U.S. by the National Fireplace Institute® (NFI) as NFI Gas Specialists.

**INSTALLER:
 Leave this manual with the appliance.
 CONSUMER:
 Retain this manual for future reference.**



**Systèmes De Brûleur:**

GF-16/18-11(P)
GF-24-11(P)
GF-30-11(P)

Ensembles De Notation :

Charred Aged Split Oak
CHAS-(16/18, 24, 30)
Charred Frontier Oak
CHFR-(16/18, 24, 30)



En cheminées avec les portes de verre, cet ensemble de notation peut être employé avec les portes de verre ouvertes ou fermées.

**POUR L'INSTALLATION EN
CHEMINÉES BRÛLANTES DE
COMBUSTIBLE SOLIDE***

**CONCEPTION CERTIFIÉE
à**

**Vented Decorative Appliance
ANSI Z21.60b-2004
CSA 2.26b-2004**

BRÛLEUR DE SÉRIE DE GF**AVERTISSEMENT**

Si l'information en ce manuel n'est pas suivie exactement, une incendie ou une explosion peut résulter, entraînant des dégâts matériels, des blessures, ou la perte de la vie.

Ne stockez pas ou n'employez pas l'essence ou d'autres vapeurs et liquides inflammables à proximité de ceci ou d'aucun autre appareil.

CE QUI À FAIRE SI VOUS SENTEZ LE GAZ:

- Ouvrez une fenêtre.
- N'essayez pas de n'allumer aucun appareil.
- Ne touchez aucun commutateur électrique; n'utilisez aucun téléphone dans le bâtiment.
- Appelez immédiatement le fournisseur de gaz du téléphone du voisin. Suivez les instructions du fournisseur de gaz.
- Si vous ne pouvez pas atteindre le fournisseur de gaz, appelez le département de feu.

L'installation et le service doivent être assurés par un installateur qualifié et professionnel, l'agence de service, ou le fournisseur de gaz.

Cet appareil sert seulement avec le type de gaz indiqué de la plaque de contrôle.

INSTALLATEUR :

Laissez ce manuel avec l'appareil.

CONSOMMATEUR:

Maintenez ce manuel pour la future référence.

**IMPORTANT: LISEZ CES INSTRUCTIONS
SOIGNEUSEMENT AVANT DE
COMMENCER L'INSTALLATION DE
L'UNITÉ.**

Le Vrai-Fyre système de brûleur doit être installée seulement dans une cheminée brûlante de combustible solide avec une conduite de cheminée fonctionnante et être construit avec du matériel non-combustible. L'installation, y compris des dispositions pour l'air de combustion et de ventilation doit se conformer au code national de gaz de carburant, la norme ANSI Z223.1/NFPA 54, ou le CSA B149.1, code d'installation de gaz naturel et de propane, et codes du bâtiment locaux applicables.

Une bride plus humide est incluse pour maintenir l'ouverture permanente minimum de passage et pour empêcher la pleine fermeture de la lame plus humide. **L'amortisseur de cheminée DOIT être entièrement ouvert en brûlant l'unité. L'unité est conçue pour brûler avec les flammes jaunes; ainsi à ventilation proportionnée est absolument nécessaire.**

Pour se conformer à la certification, les listes, et les acceptations de codes du bâtiment, et pour l'exploitation sûre et l'exécution appropriée de ce système de brûleur, utilisent SEULEMENT des pièces et des accessoires de Peterson. L'utilisation d'autres commandes, pièces, et accessoires qui ne sont pas conçus pour l'usage avec de Real-Fyre systèmes de brûleur est interdite et videra toutes les garanties, certifications, listes, et approbations de codes du bâtiment, et peut causer des dégâts matériels, le dommage corporel, ou des pertes humaines.

***Note:** des Plein-carburants ne seront pas brûlés dans une cheminée où un appareil décoratif est installé.



We recommend that our gas hearth products be installed and serviced by professionals who are certified in the U.S. by the National Fireplace Institute® (NFI) as NFI Gas Specialists.

Tested &
Listed By



Portland
Oregon USA

OMNI-Test Laboratories, Inc.

254-L-06-5

TABLE OF CONTENTS

GENERAL INFORMATION AND SPECIFICATIONS	4
DAMPER CLAMP INSTRUCTIONS	4
PARTS LIST	5
BURNER INSTALLATION	6
EMBER & LAVA ROCK PLACEMENT	7
LOG LIST	7
LOG PLACEMENT	8
LIGHTING INSTRUCTIONS - SERIES 11 VALVE	11
THERMAL RESET SWITCH - OPERATION	12
CLEANING AND SERVICING	13
FLAME DESCRIPTION	13
TROUBLESHOOTING	14
WARRANTY	16

GENERAL INFORMATION AND SPECIFICATIONS

DO NOT USE the gas log set if any part has been underwater. Immediately call a qualified service technician to inspect the gas log set and to replace any part of the control system and any gas control which has been underwater.

Peterson Real-Fyre® gas logs must be installed only in a wood burning fireplace with the minimum venting requirements met (see table on this page). Gas supply pipe must be 1/2" minimum interior diameter. If the gas line is longer than 20', a larger diameter line may be necessary.

DO NOT INSTALL the log set where completely sealed doors are used. Doors must have a combined air gap opening of no less than 18 square inches.

A fireplace screen must be in place when the system is burning. Provisions for adequate combustion air must be maintained. Unless other provisions for combustion air are provided, the screen shall have an opening(s) for introduction of combustion air. Combustion air is adequate when all flames curl into

the fireplace and away from the screen.

The gas log set must be isolated from the gas supply piping system by closing its individual shut-off valve during any pressure testing of the gas supply system at test pressures equal to or less than 1/2 psig. The gas log set and its individual shut-off valve must be disconnected from the gas supply piping system when testing at pressures in excess of 1/2 psig.

Keep the area of the gas log set clear and free from combustible materials, gasoline, and other flammable vapors and liquids.

The minimum inlet gas supply pressure for purpose of input adjustment is 5" for natural gas and 11" for propane gas. Maximum inlet gas supply pressure for this burner is 10.5" for natural and 13" propane gas.

The minimum firebox dimensions in which the log set is certified to be installed, are listed in the table below.

Maintenance and service must be performed by the gas supplier, or other qualified professional.

Burner Model	Minimum Fireplace Size			BTU Rating	
	Width	Depth	Height	Natural Gas	Propane Gas
GF-16/18-11(P)	20"	15"	17"	35k	31k
GF-24-11(P)	27"	15"	17"	45k	41k
GF-30-11(P)	32"	15"	17"	55k	51k

Minimum permanent free opening area of chimney damper for venting						
For factory-built fireplaces				For masonry-built fireplaces		
Chimney height	16/18"	24"	30"	16/18"	24"	30"
15'	22 sq. in.	28 sq. in.	34 sq. in.	26 sq. in.	32 sq. in.	38 sq. in.
20'	20 sq. in.	25 sq. in.	31 sq. in.	24 sq. in.	29 sq. in.	35 sq. in.
30'	18 sq. in.	23 sq. in.	28 sq. in.	22 sq. in.	27 sq. in.	32 sq. in.

Note: The minimum chimney height from hearth to top of chimney is 15'.

DAMPER CLAMP INSTRUCTIONS

The damper clamp with hex bolt (Fig. 4-1) is provided as a means to prevent full closure of the damper blade. The clamp is easily attached to most damper blades with pliers or a wrench, and must be permanently installed. The clamp is designed to prevent accidental closure of the damper when installed as illustrated (Fig. 4-2 and Fig. 4-3). Should the clamp not fit, or fail to provide the permanent vent opening listed in the table found above, have a permanent stop installed, remove the damper blade, or have the damper cut to provide the minimum permanent opening required.

Note: These are minimum damper opening specifications. The damper must be completely opened when operating this gas appliance to achieve the best ventilation possible.

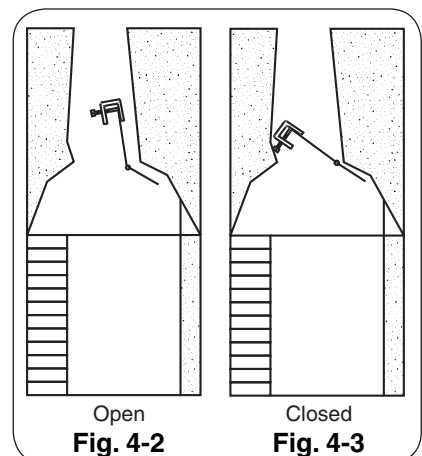
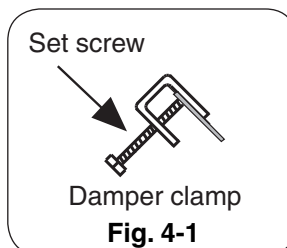

PARTS LIST

Replacement parts can be ordered from your local Real Fyre® dealer.

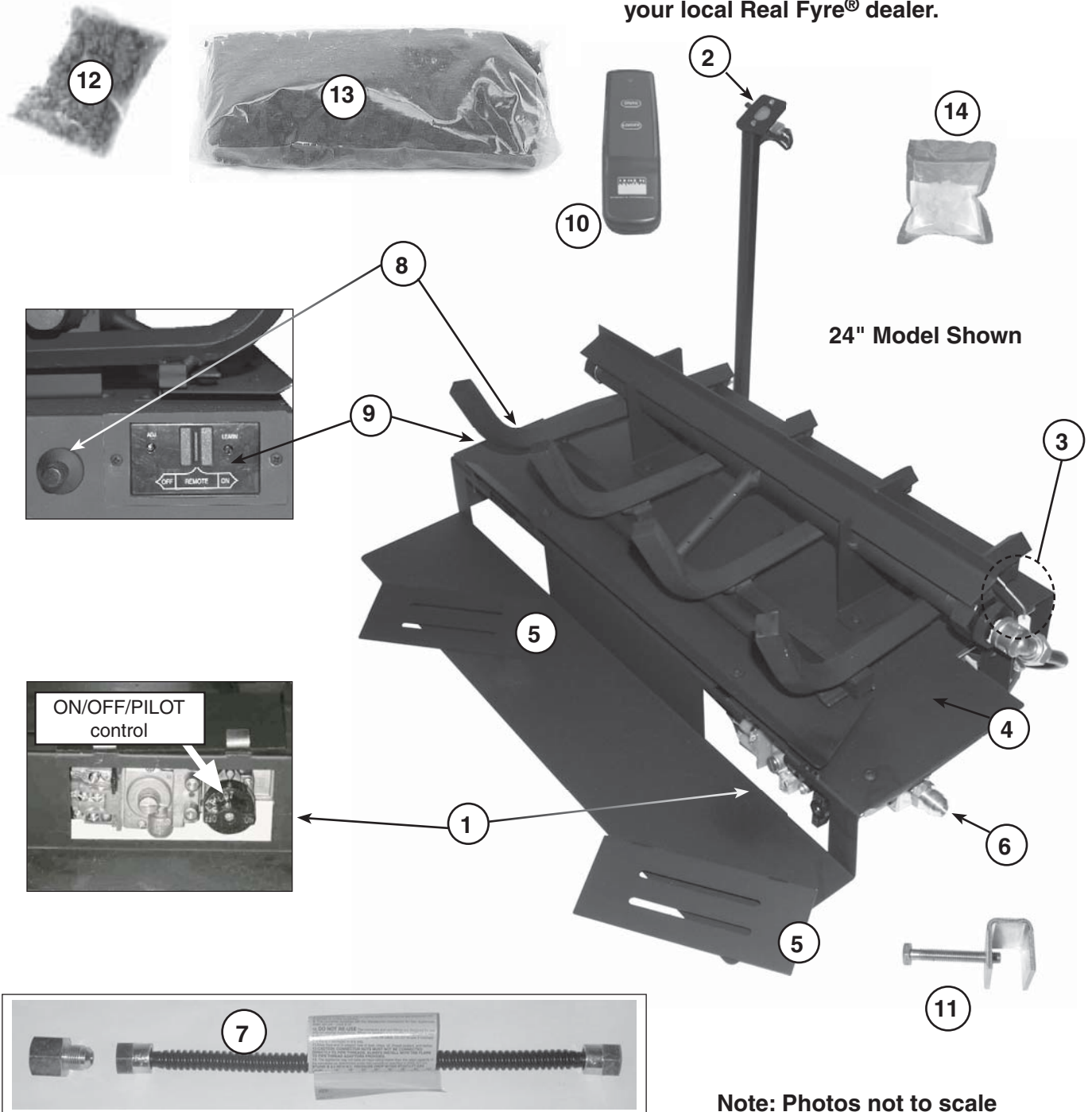

Note: Photos not to scale

ITEM NO.	DESCRIPTION
1.	Control valve
2.	Thermal reset switch
3.	Pilot assembly
4.	Base assembly with burner and grate
5.	Access doors (2)
6.	Gas fitting (flare)
7.	Connector kit

ITEM NO.	DESCRIPTION
8.	Piezo ignitor button
9.	Remote receiver
10.	Remote
11.	Damper clamp
12.	Glowing embers
13.	Lava rocks
14.	Bryte Coals™

BURNER INSTALLATION

WARNING: Failure to position the parts in accordance with these diagrams or failure to use only parts specifically approved with this appliance may result in property damage or personal injury.

Setting the thermal reset switch bracket into its operating position

This GF series burner comes equipped with a **thermal reset switch** located at the rear of the unit. To avoid damage during delivery, the switch is packed horizontally with one screw securing it into place (see Fig. 6-1). The thermal switch bracket must be moved to the vertical position before the burner system is installed in the fireplace. To accomplish this, remove the screw attached to the back of the burner assembly (see Fig. 6-2). Rotate the bracket around the rivet until it is vertical and the bracket hole lines up with the empty screw hole. Insert the screw into the holes and tighten it down with a screwdriver to lock the bracket in the vertical position (see Fig. 6-3).

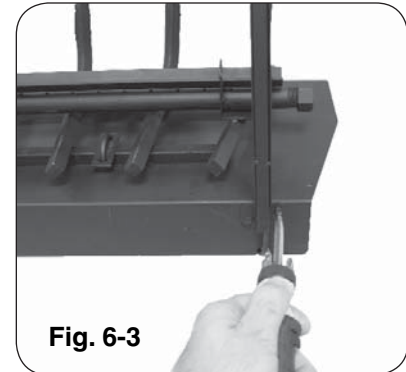
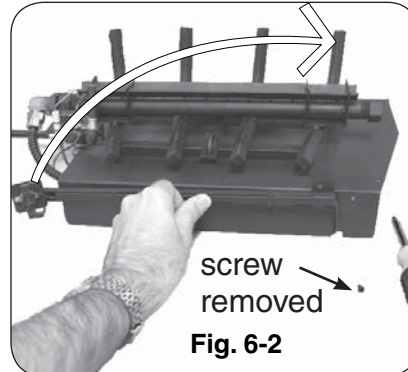
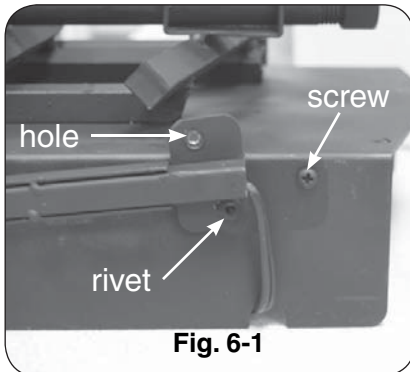

Reference the THERMAL SWITCH OPERATION section.

The Peterson Real-Fyre® gas log set must be installed by a qualified professional technician. Instructions must be followed carefully to ensure proper performance and full benefit from the gas log set.

1. Remove all items from the carton and **check the PARTS LIST on the previous page to be sure all parts are included.**
2. **Shut off the gas to the fireplace.**
3. Place the burner assembly into the fireplace so that the controls face the room.
4. Remove the cap from the gas stub.
5. Connect the large flare fitting on the flex connector to the gas stub. If Teflon tape or pipe compound is applied to the gas stub, use a compound that is resistant to all gasses.
6. Attach the flex connector kit to the adapter on the valve and tighten (Fig. 6-4).
7. Turn on the gas to the fireplace and test for leaks with a soapy water solution. **(Never use open flame for testing.) If a leak is found, tighten the adapter until no leaks are detected.**

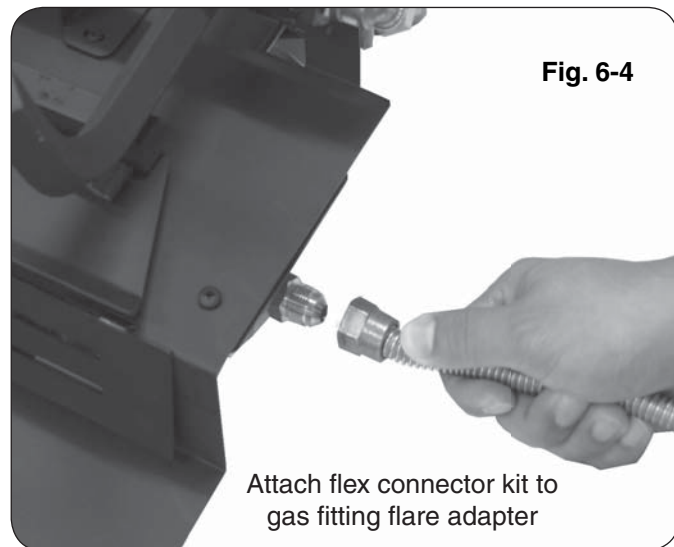

EMBER & LAVA ROCK PLACEMENT

EMBER PLACEMENT

Sprinkle the glowing embers (see PARTS LIST) lightly and evenly over the entire surface of the ember burner screen. **Break up any clumps that may have developed during shipment.** Bryte Coals™ should be placed over the glowing embers, also spread out evenly (Fig. 7-1). Failure to follow these instructions will result in unsafe operation.

Important: Do not add any additional embers or Bryte Coals™ to this log set. Any additional embers may cause unsafe operation.

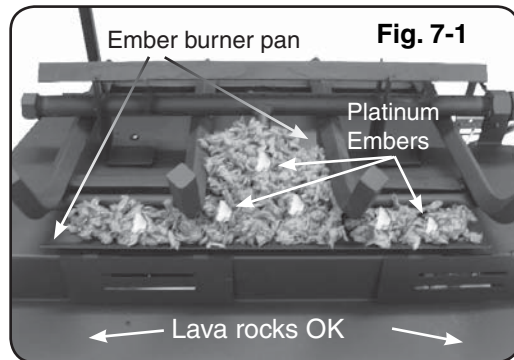

LAVA ROCKS (DECORATIVE)

Spread the lava rocks (see PARTS LIST) on the bottom of the fireplace, around (but **NOT** on) the upper burner pan.

Note: It is OK to allow lava rocks onto the portion of the burner that is resting directly on the fireplace floor, as long as they do not interfere with the controls.

IMPORTANT

For all valves, the air **MUST** be purged from the gas line before the pilot will light and burn properly. The time needed to purge will depend on the length of the gas line to the unit and the amount of time since the unit or gas line was last used. It may take several minutes before all the air is purged and the pilot will light and burn properly. Reference the LIGHTING INSTRUCTIONS section in this manual.

LOG LIST

16/18" Log Sets (CHFR-16/18 shown)

ITEM NO.	DESCRIPTION
1.	Front bottom log
2.	Rear bottom log
3.	Left middle log
4.	Right middle log
5.	Top center log

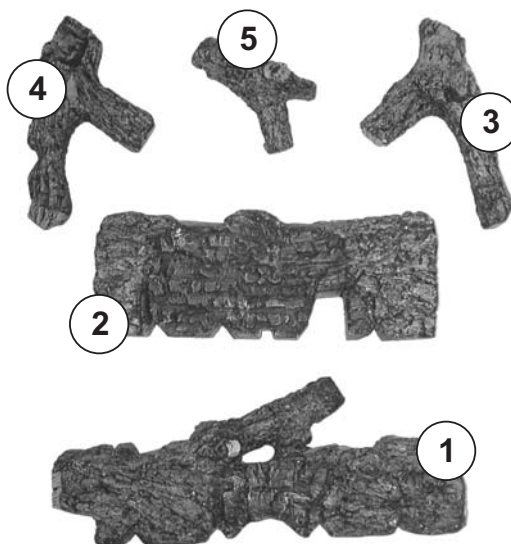

24" & 30" Log Sets (CHFR-24 shown)

ITEM NO.	DESCRIPTION
1.	Front bottom log
2.	Rear bottom log
3.	Left middle log
4.	Right middle log
5.	Left top log
6.	Right top log
7.	Top center log

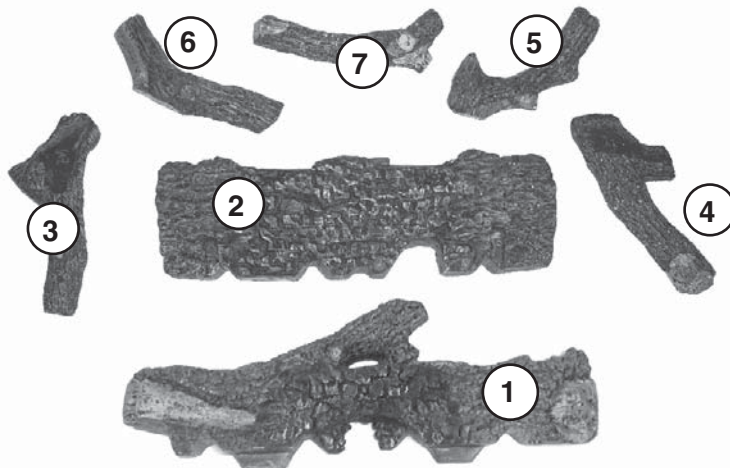

Note: The log set is packed separately.

LOG PLACEMENT

Proper log placement is important to ensure proper performance of the gas burner system. Be sure to follow the log placement instructions carefully, referring to the figures where appropriate.

16/18" LOG SETS

PLACEMENT OF BOTTOM LOGS

1. Place the rear bottom log (#2) on the back of the grate and center it side to side. Be sure that the notches in the bottom of the log rest securely over the grate fingers. There must be a clearance between the rear log and the pilot assembly located on the right side of the burner. See Fig. 8-1 and 8-2. Place the front bottom log (#1) on the front part of the grate and center it side to side. Be sure that the notches in the bottom and front of the log rest securely over the grate fingers. See Fig. 8-2.

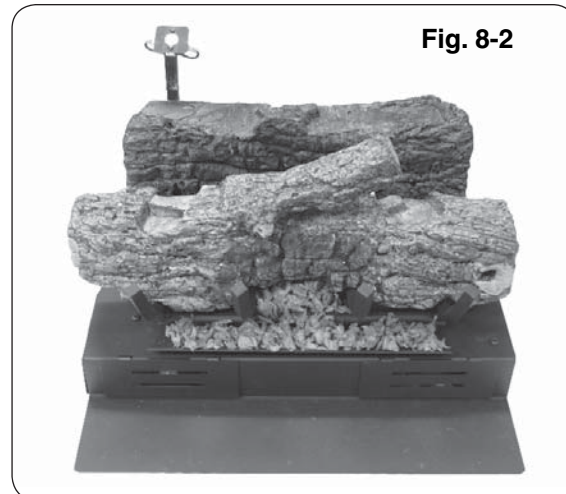
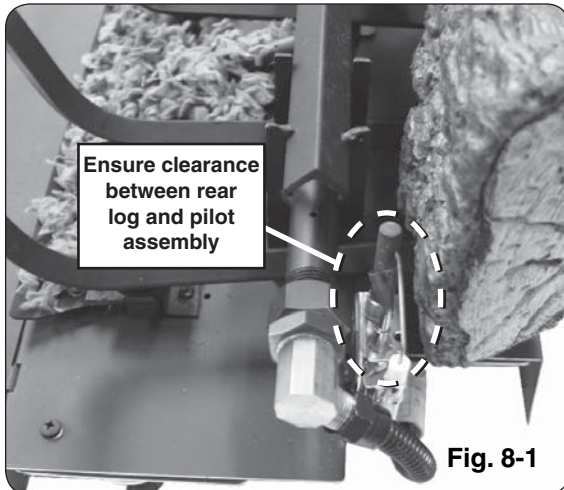

PLACEMENT OF MIDDLE AND TOP LOGS

2. Place the middle logs (#3 and #4) so that they rest on the bottom logs as shown in Fig. 8-3. Be sure that the middle logs rest securely over the grooves and notches located on the bottom logs.
3. Complete log placement by securing the top center log (#7) over the grooves and notches located on the middle logs (see Fig. 8-4).



CAUTION: BURN HAZARD! Logs will remain hot for some time after use. You must maintain the log layout as shown to ensure proper operation of your log set. If you need to reposition any log to maintain the proper layout, use heat-resistant gloves or allow logs adequate time to cool before handling.

24" AND 30" LOG SETS

1. Place the rear bottom log (#2) on the back of the grate and center it side to side. Be sure that the notches in the bottom of the log rest securely over the grate fingers. There must be a clearance between the rear log and the pilot assembly located on the right side of the burner. See Fig. 9-1 and 9-2. Place the front bottom log (#1) on the front part of the grate and center it side to side. Be sure that the notches in the bottom and front of the log rest securely over the grate fingers. See Fig. 9-2.

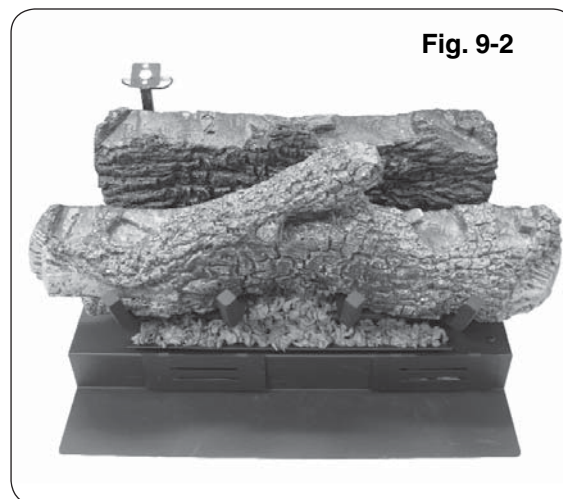
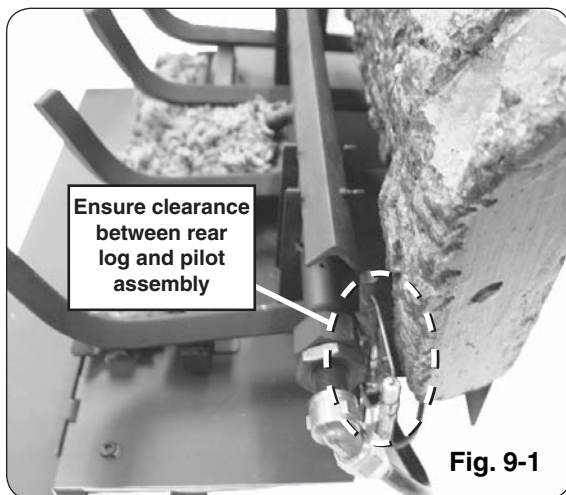

PLACEMENT OF MIDDLE AND TOP LOGS

2. Place the middle logs (#3 and #4) so that they rest on the bottom logs as shown in Fig. 9-3. Be sure that the middle logs rest securely over the grooves and notches located on the bottom logs.
3. Place the left and right top logs (#5 and #6) so that they rest on the bottom logs as shown in Fig. 9-4. Be sure that the top logs rest securely over the grooves and notches located on the bottom logs. Complete log placement by securing the top center log (#7) over the grooves and notches located on the middle logs.



INSTRUCTIONS D'ÉCLAIRAGE - VALVE DE LA SÉRIE 11

POUR VOTRE SÛRETÉ, LISEZ AVANT DE S'ALLUMER

AVERTISSEMENT : Si vous ne suivez pas ces instructions exactement, un incendie ou une explosion peut résulter entraînant des dégâts matériels, des blessures ou la perte de la vie.

N'employez pas cet appareil si n'importe quelle partie a été sous-marine. Réclamez immédiatement un technicien de service professionnel qualifié et pour inspecter l'appareil et pour remplacer n'importe quelle partie du système de commande et de n'importe quelle commande de gaz qui a été sous l'eau.

Le Vrai-Fyre® système de brûleur a un pilote qui peut être allumé en employant construit dans le passage d'ignitor de piezo sur le brûleur, ou employer à la main une allumette ou désirer ardemment allumeur étranglé. En allumant le pilote, suivez ces instructions exactement.

AVANT DE S'ALLUMER, sentez tous autour du secteur de brûleur pour le gaz. Soyez sûr de sentir à côté du plancher car un certain gaz est plus lourd que l'air et arranger sur le plancher. **SI VOUS SENTEZ LE GAZ, SUIVEZ LES INSTRUCTIONS À LA P. 1.**

Utilisez seulement votre main pour enfoncer ou pour tourner le bouton de commande de gaz. N'utilisez jamais les outils. Si le bouton n'enfoncera pas ou ne tournera pas à la main, n'essayez pas de le réparer. Appelez un technicien de service professionnel qualifié et. La force ou la réparation essayée peut avoir comme conséquence l'incendie ou l'explosion.

ALLUMANT LE PILOTE

Pour lire le bouton de commande de soupape de sûreté (Fig. 10-1) lisez l'indicateur formé par larme la plus proche en métal d'inscription.

1. Si le bouton de commande de soupape de sûreté est en position **PILOT**, enfoncez légèrement sur le bouton et tournez-le dans le sens des aiguilles d'une montre jusqu'à la position de **OFF**.
2. Libérez le bouton et attendez cinq minutes.
3. Tournez le bouton de soupape de sûreté dans le sens contraire des aiguilles d'une montre à la position **PILOT** (seulement le gaz pilote coulera quand le bouton est enfoncé).
4. Poussez et tenez le bouton de soupape de sûreté entièrement dedans et enfoncez le bouton d'ignitor de piezo plusieurs fois jusqu'aux lampes témoin.
5. Tenez le bouton de soupape de sûreté dedans pendant approximativement 60 secondes avant de libérer.
6. **Si le pilote ne reste pas s'allumait**, la position de **OFF** de bouton de soupape de sûreté dans le sens des aiguilles d'une montre entièrement. Attendez cinq minutes, puis répétez les étapes 3. à 5.

ALLUMAGE DU BRÛLEUR PRINCIPAL

Avec le pilote allumé, tournez le bouton de soupape de sûreté dans le sens contraire des aiguilles d'une montre à la position de fonctionnement. Commutez le récepteur à distance à la position de fonctionnement, et le brûleur s'allumera. Référez-vous à la LISTE DE PIÈCES pour l'endroit à distance de récepteur.

ARRÊT DU BRÛLEUR PRINCIPAL

Commutez le récepteur à distance à la position de repos. Le pilote restera sur.

ARRÊT DU PILOTE

Soyez sûr que le récepteur à distance est éteint et enfoncez et tournez le bouton de soupape de sûreté dans le sens des aiguilles d'une montre à la position de repos.

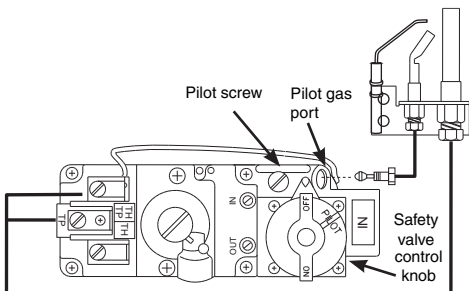

Fig. 10-1

AJUSTANT LE PILOTE

1. La flamme pilote devrait encercler le bout de générateur, et est préréglée à l'usine (Fig. 10-2).
2. Si l'ajustement est nécessaire, (Fig. 10-1) tournez la vis d'approche de gaz dans le sens contraire des aiguilles d'une montre pour augmenter la flamme pilote, ou pour diminuer dans le sens des aiguilles d'une montre la flamme pilote.

ENTRETIEN

Votre brûleur à casserole est équipé d'un pilote de sûreté qui coupera l'offre de gaz au cas où le pilote serait ne brûlant pas ou ne fonctionnant pas correctement. Assurez-vous que le pilote est ajusté correctement et que les agrafes de cosse de générateur sont étroitement reliées aux vis terminales sur la valve. Si le pilote ne restera pas allumait, appellez votre utilité de gaz ou fournisseur locale de gaz.

Un contrôle périodique du suivant devrait être exécuté au moins annuellement par un représentant qualifié de service professionnel.

1. Valves et récepteur à distance pour l'opération appropriée.
2. Système de conduite de cheminée pour la rouille, les dommages, ou les fuites.
3. Une opération plus humide.
4. Orifices pour la saleté ou d'autres corps étrangers.
5. Contrôle visuel sur le brûleur.

En plus de ces instructions, lisez et suivez les instructions à distance séparées d'actionner le brûleur à distance.

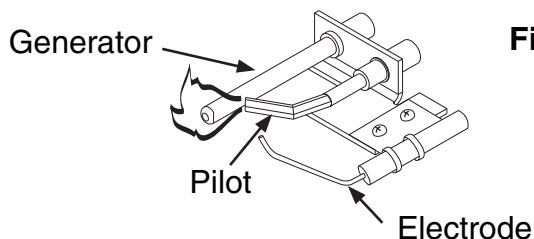

Fig. 10-2

Note: La flamme pilote devrait encercler le dessus du générateur

LIGHTING INSTRUCTIONS - SERIES 11 VALVE

FOR YOUR SAFETY, READ BEFORE LIGHTING

WARNING

If you do not follow these instructions exactly, a fire or explosion may result, causing property damage, personal injury, or loss of life.

Do not use this appliance if any part has been underwater. Immediately call for a qualified professional service technician to inspect the appliance and to replace any part of the control system and any gas control that has been underwater.

The Real-Fyre® burner system has a pilot that can be lit by using the built-in piezo ignitor on the burner, or by hand using a match or long-necked lighter. When lighting the pilot, follow these instructions exactly.

BEFORE LIGHTING, smell all around the burner area for gas. Be sure to smell next to the floor, as some gas is heavier than air and will settle on the floor. IF YOU SMELL GAS, FOLLOW THE INSTRUCTIONS ON P. 1.

Use only your hand to push in or turn the gas control knob. Never use tools. If the knob will not push in or turn by hand, don't try to repair it. Call a qualified professional service technician. Force or attempted repair may result in fire or explosion.

LIGHTING THE PILOT

To read the safety valve control knob (Fig. 11-1), read the marking nearest the teardrop-shaped metal pointer.

1. If the safety valve control knob is in the **PILOT** position, push in slightly on the knob and rotate it clockwise ↻ to the **OFF** position.
2. Release knob and wait five (5) minutes.
3. Turn safety valve knob counterclockwise ↶ to the **PILOT** position. (Only the pilot gas will flow when the knob is pushed in.)
4. Push and hold the safety valve knob fully in and push in the piezo ignitor button several times until the pilot lights.
5. Hold the safety valve knob in for approximately 60 seconds before releasing.
6. **If the pilot does not stay lit**, turn the safety valve knob clockwise ↻ to the full **OFF** position. Wait five (5) minutes, then repeat steps 3 through 5.

IGNITING THE MAIN BURNER

With the pilot lit, turn the safety valve knob counterclockwise ↶ to the **ON** position. Switch the remote receiver to the **ON** position, and the burner will light. Refer to the PARTS LIST for the remote receiver location.

SHUTTING OFF THE MAIN BURNER

Switch the remote receiver to the **OFF** position. The pilot will remain lit.

SHUTTING OFF THE PILOT

Be sure the remote receiver is **OFF** and depress and turn the safety valve knob clockwise ↻ to the **OFF** position.

ADJUSTING THE PILOT

- a. The pilot flame should encircle the generator tip, and is preset at the factory (Fig. 11-2).
- b. If adjustment is necessary (Fig.11-1), turn the gas adjustment screw counterclockwise ↶ to increase the pilot flame, or clockwise ↻ to decrease the pilot flame.

MAINTENANCE

Your pan burner is equipped with a safety pilot that will shut off the gas supply in the event that the pilot is not functioning properly. Make sure the pilot is adjusted properly and that the generator spade clips are tightly connected to the terminal screws on the valve. If the pilot will not stay lit, call your local gas utility or gas supplier.

A periodic check of the following should be performed at least annually by a qualified professional service representative:

1. Valves and remote receiver for proper operation.
2. Flue system for rust, damage, or leaks.
3. Damper operation.
4. Orifices for dirt or other foreign matter.
5. Visual check on the burner.

In addition to these instructions, read and follow the separate remote instructions to operate the burner remotely.

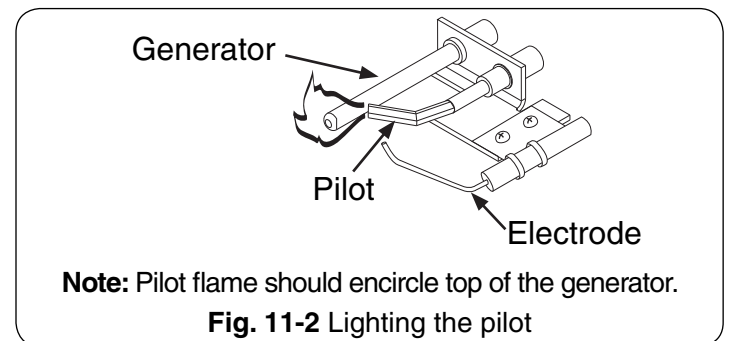
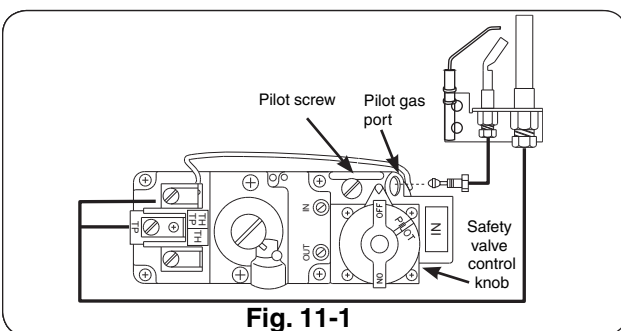

THERMAL RESET SWITCH - OPERATION

This gas log set is equipped with a safety thermal reset switch, located at the **rear left** of the burner (see Fig. 12-1). If the chimney will not properly vent, or is blocked when the burner is in operation, the system will shut down. The pilot will remain lit. Call a qualified technician to check the unit. Have the chimney cleaned and inspected to ensure proper venting.

TO RESET THE THERMAL SWITCH

1. **Wait for the fireplace temperature to cool down** *before opening the glass doors.*
2. Turn the remote receiver on the left side of the burner to **OFF**. Turn the control knob on the front right of the burner to **OFF**.
3. Ensure the damper is fully open.

CAUTION: LOG SET MAY BE HOT - AVOID TOUCHING LOGS OR BURNER PARTS.

4. Carefully reach to the underside of the thermal switch and press it up (see Fig. 12-1). A click may be heard.
5. **Relight the pilot** per the LIGHTING INSTRUCTIONS section.

If the problem persists remove the damper completely.

If the problem still continues, contact the local dealer.

CAUTION: THE DAMPER MUST BE FULLY OPEN WHEN BURNING THE LOG SET.

Fig. 12-1

CAUTION: Before resetting, ensure control knob is in the **OFF** position.

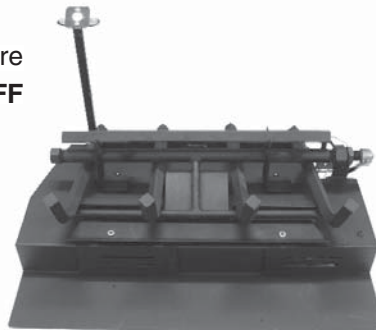

Thermal reset switch located at rear of gas burner



To reset, press button up

CLEANING AND SERVICING

Note: Regular cleaning and servicing will be necessary to ensure proper pilot operation and proper burn characteristics.

Always shut off the gas to the appliance while performing service work.

Allow the appliance to cool before servicing.

Installation, service, and repair must be done by an NFI Certified or other qualified professional service technician. The appliance MUST be inspected before use, and cleaned at least annually to prevent burner shutdown, sooting, odors, etc. by a qualified professional service technician. It must be checked for clean burning operation and proper pilot appearance, with the correct tools to service this unit. More frequent cleaning may be required. Excessive lint can build up on this unit from carpeting, bedding material, pet hairs, or other particles in the air. It is imperative that all control components and compartments, burner(s), air shutters, and circulating air passageways of the appliance be kept clean and free of all obstructions.

In addition, a periodic examination and cleaning (annually) of the venting system and the solid-fuel-burning fireplace should be conducted by a qualified professional service technician.

Any safety screen or guard removed for servicing must be replaced prior to operating this appliance.

TO CLEAN THE BURNER SYSTEM

1. Remove the log set and embers. Use a vacuum cleaner to remove loose particles from all surfaces of the burner log set. Do not use cleaning fluids.
2. Dust the grate, the assembly, and the burners. Using a compressed air duster (commonly available at computer, electronic, or office supply stores); blow through all of the burner ports, and the pilot assembly area.
3. Replace batteries as needed.
4. Reinstall the log set and embers as instructed in this manual.

If, after a period of use, the flames start to exhibit unusual shapes and behavior, or the burners fail to ignite smoothly, the burner ports may require some cleaning. If this happens, it is preferable to contact the nearest dealer to get the appliance serviced.

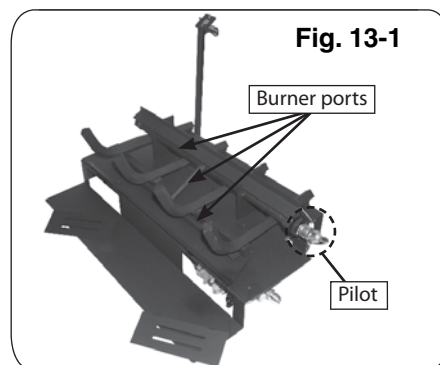

Do not remove the rating plates or the warning tags. These are an integral safety and identification component of this appliance.

We recommend following these instructions at the beginning of each fireplace season and as needed throughout the year, depending on your usage pattern and the environmental conditions in your home. More frequent cleaning and maintenance may be necessary when burning propane gas than with natural gas.

FLAME DESCRIPTION

Observe the flames. The main burner flames should be blue at the base and a combination of blue/yellow at the body and at the tips. They should be approximately 5-8" above the logs, with the center flame being the tallest. The ember flames should be 1/4" to 5" above the embers (See 13-2 for example.)



Fig. 13-2 Flame appearance

TROUBLESHOOTING

POSSIBLE CAUSE	SOLUTIONS
1 BURNER SHUTTING DOWN DURING OPERATION	
A. Insufficient or excessive gas pressure	A1. Check gas pressure (check with local gas company). A2. Other gas appliances may be on the same gas line, dropping gas pressure to log set. Check pressures with everything operating to ensure adequate pressure.
B. Log placement	B. Reference the LOG PLACEMENT section in this manual for recommended log positioning.
C. Flue area, fireplace, or damper dirty from soot	C. Clean around, above, and under damper thoroughly. Clean fireplace, removing loose material, including soot and creosote.
D. Fireplace too small for unit	D. Ensure minimum requirements are met. (See FIREPLACE SIZE REQUIREMENT section in this owner's manual.)
E. Pilot flame lifting off thermocouple/generator	E. Check gas pressure (see section A1).
F. Pilot (remote compatible)	F. Contact your dealer for instructions on replacement.
G. Closed damper or blocked flue	G. Open the damper and have the flue and chimney cleaned. Reset safety thermal switch (see THERMAL RESET SWITCH section).
2 PILOT WILL NOT LIGHT	
A. Pilot flame lifting off thermocouple/generator	A. Check gas pressure (check with local gas company).
B. Electronic spark not lighting pilot	B. Check to assure sparking when activated. Note: You may need to turn or press ignitor several times to ignite pilot. See LIGHTING INSTRUCTIONS for your control valve.
C. Ignitor electrode wire loose	C. Check wiring and reconnect any loose wiring.
D. Gas supply off/manual shutoff valve closed	D. Turn on gas supply or open manual shutoff valve.
E. Air in gas line	E. Bleed the gas supply line and repeat LIGHTING INSTRUCTIONS until air is removed.
F. Pilot hood blocked	F. Check for debris or dirt / Clean pilot
G. Dead batteries (electronic pilots only)	G. Replace batteries as needed.
3 LOW FLAME HEIGHT	
A. Gas pressure	A. Check gas pressure (check with local gas company).
B. Propane tank running low	B. Fill tank completely.
4 BURNER NOT BURNING EVENLY	
A. Burner orifice clogged	A. Clean burner orifice.
5 ODORS	
A. Gas leak	A. Shut off gas, if possible. Follow instructions on front page. Have a qualified professional installer or the gas company correct all leaks.
B. New home, new carpet, or new paint	B. When these odors are drawn into the fireplace, this may cause objectionable odors. Thoroughly ventilate the area before restarting your log set.

TROUBLESHOOTING (Cont.)

POSSIBLE CAUSE	SOLUTIONS
6 SOOTING	
A. On logs, in firebox, or room	A. Check gas pressure (check with local gas company).
B. Drafts in room	B. Eliminate drafts by closing heating and air conditioning vents, returns, and outside air vents. Fans blowing directly into fireplace should be turned off when set is operating.
C. Air shutters blocked (if applicable)	C. Air shutters are blocked with debris. Vacuum debris away from air shutter.
D. Log placement	D. See solution in troubleshooting 1B.
E. Using natural-gas burner on propane gas or propane burner on natural gas	E. If the gas listed on the nameplate does not match the gas you are burning, shut down the burner system immediately and completely (including pilot) following the steps in the LIGHTING INSTRUCTIONS section. Then call your dealer.
F. Adding any accessories to log sets	F. Shut down log set and take off any logs or accessories that do not belong with the set.
7 PILOT WILL NOT STAY LIT	
A. Valve won't hold	A. Contact your dealer for instructions on replacement.
B. Pilot hood not aimed at thermocouple	B. Pilot hood bent; replace pilot or angle pilot hood properly so pilot flame hits thermocouple.
C. Pilot line bent	C. Replace pilot line.
D. Thermocouple is loose	D. Tighten thermocouple nut at gas control valve.
E. Thermocouple cracked or worn out	E. Replace thermocouple.
F. Excessive down draft	F. Install chimney cap / Outside chimney too close to other peaks / Check chimney flue for proper height / Poorly designed chimney

WARRANTY

PETERSON VENTED DECORATIVE GAS APPLIANCE LIMITED WARRANTY

All Peterson gas logs are **WARRANTED for as long as you own them (lifetime)**.

All Peterson burner assemblies are **WARRANTED for TEN (10) YEARS**.

All Peterson glass is **WARRANTED for FIVE (5) YEARS**.

SPK-26 controls are covered by a **THREE (3) YEAR "All Parts" Warranty**.

All other Peterson valves, pilots, and controls are covered by a **ONE (1) YEAR Limited Warranty (excluding batteries)**.

PLEASE KEEP A COPY OF YOUR SALES SLIP FOR PROOF OF PURCHASE

This warranty applies to the original purchaser and to single family residential use only. It commences from date of purchase, and is valid only with proof of purchase.

This warranty does not cover parts becoming defective through misuse, accidental damage, electrical damage, improper handling, lack of routine maintenance, storage, and/or installation. Product must be installed (and gas must be connected) as specified in the instructions or operator's manual, by a **qualified professional installer**. Accessories, parts, valves, remotes, etc., when used must be Peterson Co. product.

This warranty **does not** apply to rust, corrosion, oxidation, or discoloration, unless the affected component becomes inoperable. It **does not** cover labor or labor-related charges.

This warranty specifically excludes liability for **indirect, incidental, or consequential damages**. Some states do not allow the exclusion or limitation of incidental or consequential damages, so the above exclusion may not apply to you. This warranty gives you specified legal rights, and you may have other rights that may vary from state to state.

For additional information regarding this warranty, or to place a warranty claim, contact the R.H. Peterson dealer where the product was purchased.

**TO REGISTER YOUR PRODUCT ONLINE GO TO: WWW.RHPETERSON.COM,
AND CLICK ON PRODUCT REGISTRATION. THANK YOU FOR YOUR PURCHASE.**

Quality Check			Date: _____	
Burner Orifices	Nat.	L.P.	Leak Test: _____	Model#: _____
Main:	_____	_____	Burn Test: _____	Serial#: _____
Other:	_____	_____	Gas Type: <u>Nat. / L.P.</u>	Air Shutter: _____
				Inspector: _____