

AC POWERED ELECTRONIC PILOT KIT



(Suitable for G4, G45, and PB series burners)

FEATURES:

- NON-STANDING FLAME-SENSING PILOT •
- MANUAL SWITCH ON/OFF •
- AC POWER OPERATION •

EPK-1M-AD PILOT KITS

WARNING

If the information in this manual is not followed exactly, a fire or explosion may result, causing property damage, personal injury, or loss of life.

Do not store or use gasoline or other flammable vapors and liquids in the vicinity of this or any other appliance.

WHAT TO DO IF YOU SMELL GAS:

- Open a window.
- Do not try to light any appliance.
- Do not touch any electrical switch; do not use any phone in the building.
- Immediately call the gas supplier from a neighbor's phone and follow the gas supplier's instructions.
- If you cannot reach the gas supplier, call the fire department.

Installation and service must be performed by an NFI Certified or other qualified professional installer, service agency, or the gas supplier.

INSTALLER & CONSUMER

These instructions **MUST** be retained with this appliance

Important: Read these instructions carefully before starting installation of the burner control system.

The Peterson Real-Fyre® burner system is to be installed only in a solid-fuel-burning fireplace with a working flue constructed of noncombustible material. Solid fuels shall not be burned in a fireplace where the unit is installed. The installation, including provisions for combustion, ventilation air, and required minimum permanent vent opening, must conform with the *National Fuel Gas Code (ANSI Z223.1/NFPA 54)* and applicable local building codes. In Canada, the installation must conform with the *Natural Gas and Propane Storage and Handling Installation Code (CSA-B-149.1)*. A damper stop clamp is included to maintain the minimum permanent vent opening and to prevent full closure of the damper blade. **The chimney damper must be fixed fully opened when burning the unit. The burner system is designed to burn with yellow flames; thus, adequate ventilation is absolutely necessary.**



TABLE OF CONTENTS

2	TABLE OF CONTENTS
2	IMPORTANT INFORMATION
3	PARTS LIST
4	INSTALLATION
4	PREPARATION
4	ORIENTATION
4	CREATE VALVE HOUSING OPENING/FRAME
4	INSTALL THE FLAME DIVERTER BRACKET
5	INSTALL THE PILOT ASSEMBLY TO THE BURNER
5	CONNECT THE VALVE TO THE GAS SUPPLY
5	CONNECT THE VALVE TO BURNER
5	LEAK TEST
6	CHECK THE IGNITION PACK
7	CONNECT THE IGNITOR PACK TO A WALL SWITCH
7	CONNECT THE IGNITOR PACK TO A POWER SUPPLY
7	SECURE THE VALVE HOUSING
8	CONVERTING TO A DIFFERENT GAS TYPE
8	LIGHTING INSTRUCTIONS
9	TROUBLESHOOTING
10	NOTES PAGE
11	ELECTRONIC PILOT TROUBLESHOOTING
12	WARRANTY

IMPORTANT INFORMATION

CHECK TO BE SURE THAT THE PROPER FUEL GAS IS BEING USED WITH THIS PILOT KIT.

The installation, including provisions for combustion and ventilation air, must conform with local codes, or in the absence of local codes, with the National Fuel Gas Code (ANSI Z223.1/NFPA 54).

This component and its individual shutoff valve must be disconnected from the gas-supply piping system when testing at pressures that exceed 1/2 psig. This is accomplished by closing the gas-supply line valve.

This component must be isolated from the gas-supply piping system by closing its individual manual shutoff valve during any testing of the gas-supply system at test pressures up to and including 1/2 psig.

A fireplace screen must be in place when the gas burner system is in operation. Unless other provisions for combustion air are provided, the screen shall have an opening(s) for introduction of combustion air.

WHEN GLASS FIREPLACE ENCLOSURES (DOORS) ARE USED, OPERATE THE BURNER SYSTEM WITH THE GLASS DOORS FULLY OPEN; BOTH SIDES IF THE FIREPLACE IS A SEE-THROUGH TYPE.

This appliance may be installed in an aftermarket, permanently located, manufactured (mobile) home where not prohibited by local codes. Installation of appliances designed for manufactured homes or mobile homes must conform with *Manufactured Home Construction and Safety Standard, Title 24 CFR, Part 3280* in the U.S.; or with *CAN/CSA Z240 MH* in Canada; or with *ANSI/NCSBCS A225.1/NFPA 501A, Manufactured Home Installations Standard* when such as standard is not applicable.

Do not use this appliance if any part has been underwater. Immediately call a qualified service technician to inspect the appliance and to replace any part of the control system and any gas control that has been underwater.

PARTS LIST

DO NOT REMOVE THE PILOT ASSEMBLY FROM THE VALVE OR IGNITOR PACK.

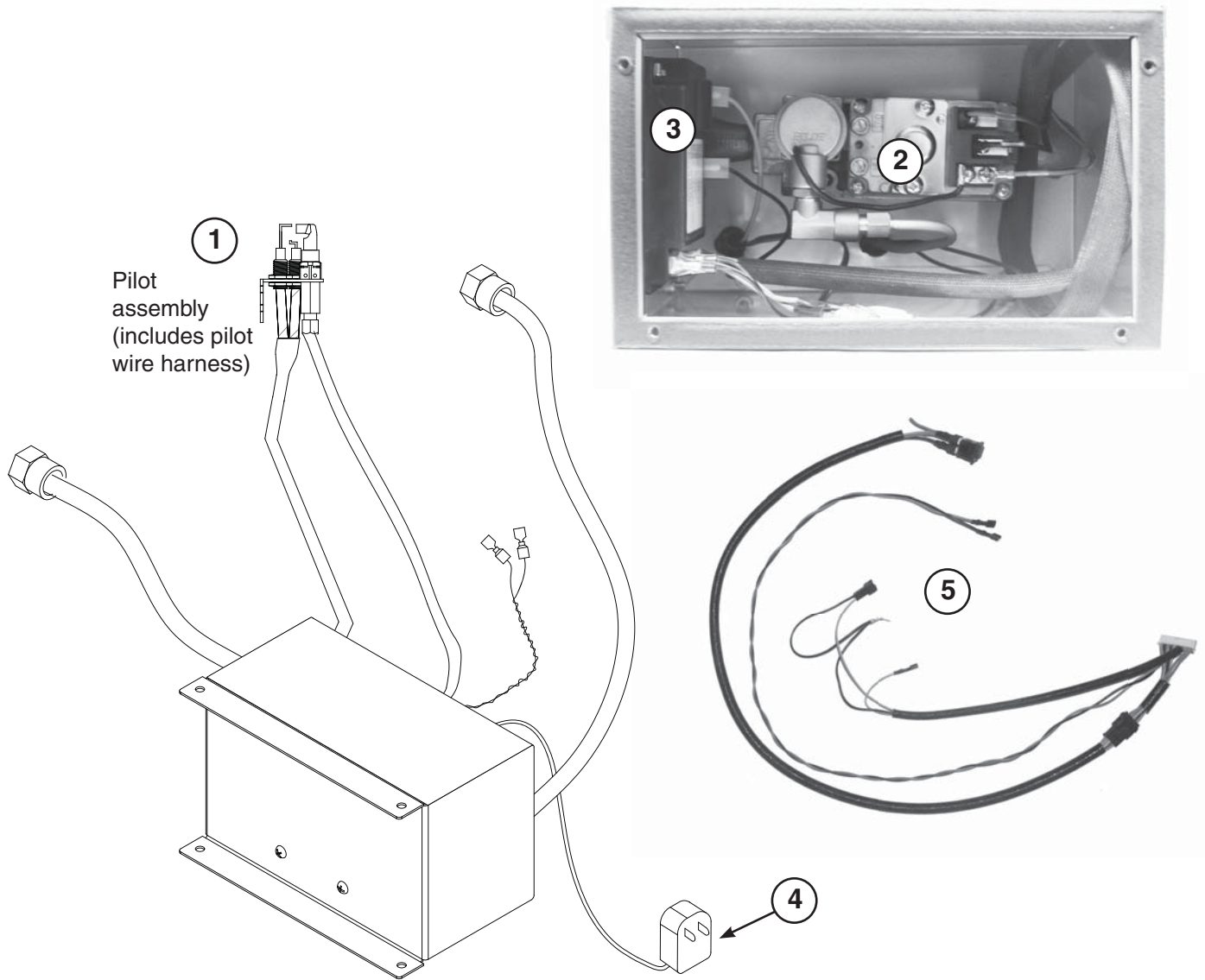

Photos not to scale

Item No.	Description
1.	Pilot assembly, natural gas or Pilot assembly, propane gas
2.	Valve, natural or propane gas
3.	Ignitor pack
4.	AC adaptor
5.	Wire harness
6.	Pilot mounting bracket
7.	Flame diverter bracket

**FOR WIRING DIAGRAM & WIRE COLORS,
SEE P. 6**

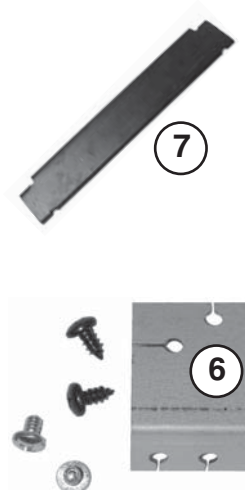

INSTALLATION

This safety pilot system must be installed by a qualified professional service technician. Instructions must be followed carefully when installing to ensure proper performance and full benefit from the burner system and safety pilot system.

These instructions must be used as a supplement to the instructions supplied with the Peterson burner system. Follow the burner system instructions and make adjustments as appropriate for the addition of a safety pilot system. Use gas pipe sealing compound that is resistant to all gasses (or Teflon tape) and apply to all male pipe connections. Make sure that all connections are tight.

PREPARATION

If the burner that the EPK valve system is to be added to is already installed; remove all decorative media, and set it aside to be reinstalled (later using the instructions that came with the original burner).

ORIENTATION

Prior to installation, please review and determine the orientation of this unit by referencing Fig. 4-1. **Be sure the location of the valve housing is within reach of the burner (for flex connector and pilot assembly), the gas supply (for flex connector), the 110V receptacle (for transformer adaptor), and the wall switch (for ON/OFF control wires).**

CREATE VALVE HOUSING OPENING/FRAME

The valve housing must be secured in an opening/frame within the allowed range of the burner as mentioned in Fig. 4-1. The cutout for the valve housing is $8\frac{5}{8}$ " wide by $5\frac{1}{2}$ " high, with a mounting plate depth of $8\frac{1}{2}$ " (see Fig. 4-2). Be sure to allow for wires/tubing clearance behind the housing. The valve housing will be secured upon completion of installation. (See SECURE VALVE HOUSING section.)

INSTALL THE FLAME DIVERTER BRACKET

For installation on G4/G45 burners only. When properly installed onto the burner pan, the flame diverter bracket will promote quicker ignition and protect the safety control system from overheating.

Note: You must first install the flame diverter bracket before installing the pilot assembly. Use only the pilot assembly pre-assembled with this kit. Never substitute with an existing pilot.

1. Place the flame diverter bracket over the side edge of the burner pan, near the location the safety control system pilot bracket will be attached. It should be placed **approximately 2-1/2"** from the rear wall of the burner pan (see Fig. 4-3).
2. Tap the bracket lightly with a hammer to secure it in place.

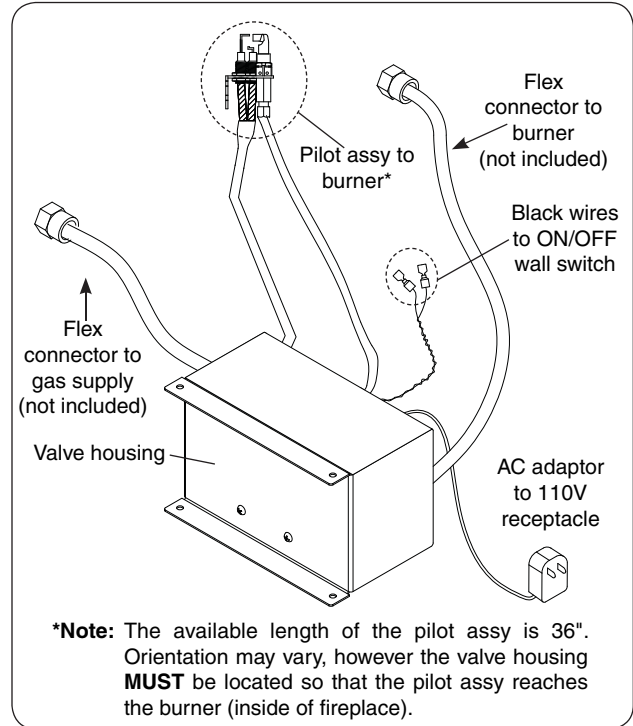

Fig. 4-1

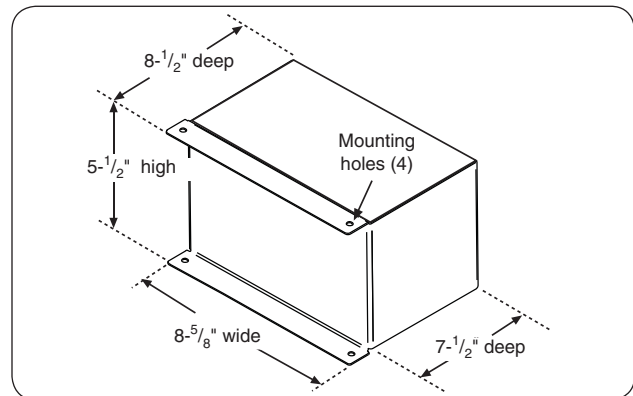

Fig. 4-2

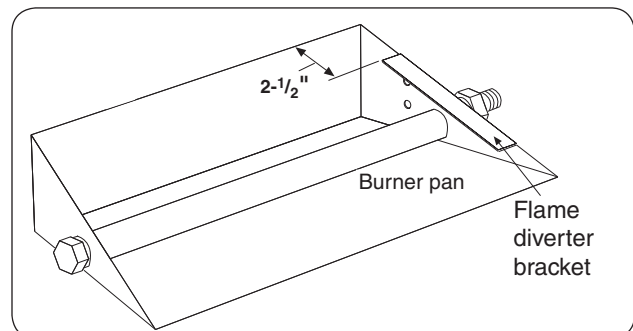

Fig. 4-3

INSTALL THE PILOT ASSEMBLY TO THE BURNER

Caution: Do not kink or damage the pilot supply tube, sparking, and sensor probes. Do not unscrew the gas line from the valve.

1. Route the pilot/igniter assembly coming from the valve system to the burner (inside of fireplace).
2. The pilot assembly comes with an L-shaped mounting bracket. Using the two black screws, fasten the bracket to burner pan (short side toward the back of the pan) using the pre-drilled holes in the pan (see Fig. 5-1).
3. Using the two (2) remaining screws, mount the pilot assembly onto the bracket (from below) and tighten until snug (Fig. 5-2). **Check to be certain the pilot hood and probes are situated above the edge of the pan. Adjust if necessary.**

WARNING: Keep the pilot/igniter assembly clear at all times. Never cover any part of the pilot/igniter assembly.

CONNECT THE VALVE TO THE GAS SUPPLY

Connect a 1/2" flex connector (not included) to the gas supply and the **IN** adapter found on the rear of the valve system. See Fig. 5-3. Be sure all connections are tight.

Important: A flex adaptor is needed to connect the valve to the gas supply (a gas pipe sealing compound or Teflon tape must be used).

CONNECT THE VALVE TO BURNER

Connect a 1/2" flex connector (not included) to the fuel injector or air mixer on the burner and the **OUT** adapter found on the rear of the valve system. See Fig. 5-4. Be sure all connections are tight.

Important: A flex adaptor is needed to connect the valve to the fuel injector or air mixer on the burner (a gas pipe sealing compound or Teflon tape must be used).

LEAK TEST

Carefully turn on the gas supply and leak test at all connections with a soapy water solution (equal parts liquid detergent and water). If bubbles appear, a leak is present. Turn off the gas and tighten all connections, then turn on the gas and repeat the leak test. Repeat until no leaks are detected. **Never use a flame to test for leaks.**

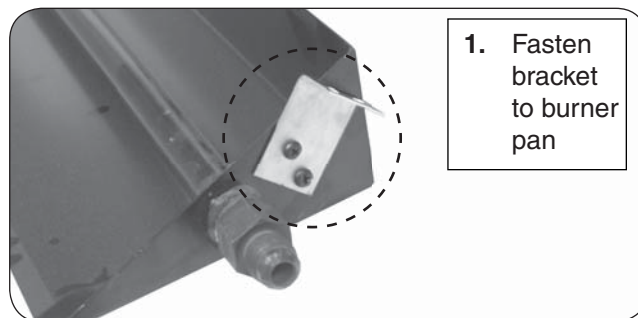

Fig. 5-1

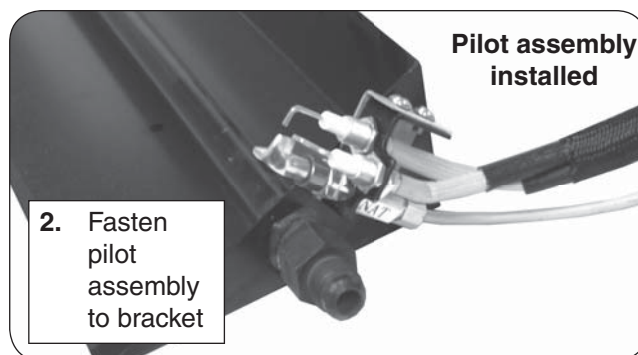

Fig. 5-2

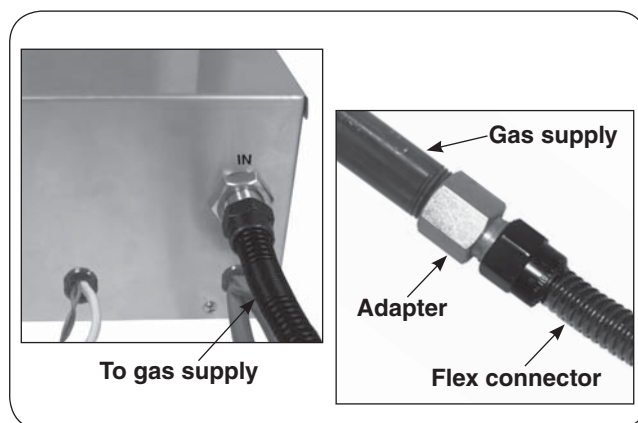

Fig. 5-3

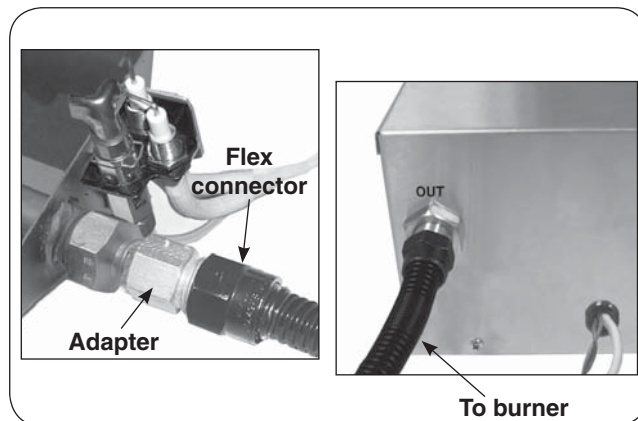

Fig. 5-4

INSTALLATION (Cont.)

CHECK THE IGNITION PACK

The EPK-1M-AD unit comes completely assembled with the wiring harness already connected to the valve and ignitor pack. The AC Adaptor and wall switch wires comes connected to the ignitor pack. We recommend that you follow the steps below to ensure they have not become detached during shipping before connecting to a power supply.

TO CHECK THE WIRING ASSEMBLY

1. Check that the wiring harness is fitted tightly into the connector on the green ignitor pack in the rear of the valve housing (Fig. 6-1).

Note: The two (2) spare black wires with coated male connectors coming from the wiring harness are used to connect to the wall switch. See Fig. 6-3 and the CONNECT THE IGNITOR PACK TO A WALL SWITCH section.

2. Check that the female connectors on the AC adaptor wires are inserted fully into the male connectors on the ignitor pack (Fig. 6-1).
3. Check that the female connectors on the two black wires from the pilot assembly (wires marked "I" and "S") are inserted fully into the male connectors on the ignitor pack (Fig. 6-1).
4. Check the connections of the wires to the valve (see Fig. 6-2):

Orange wire marked **THTP** - to **THTP** connector on valve
Black wire marked **TP** - to **TP** connector on valve
Green wire marked **TH** - to **TH** connector on valve

The diagram below (Fig. 6-3) shows the wiring layout for the complete unit.

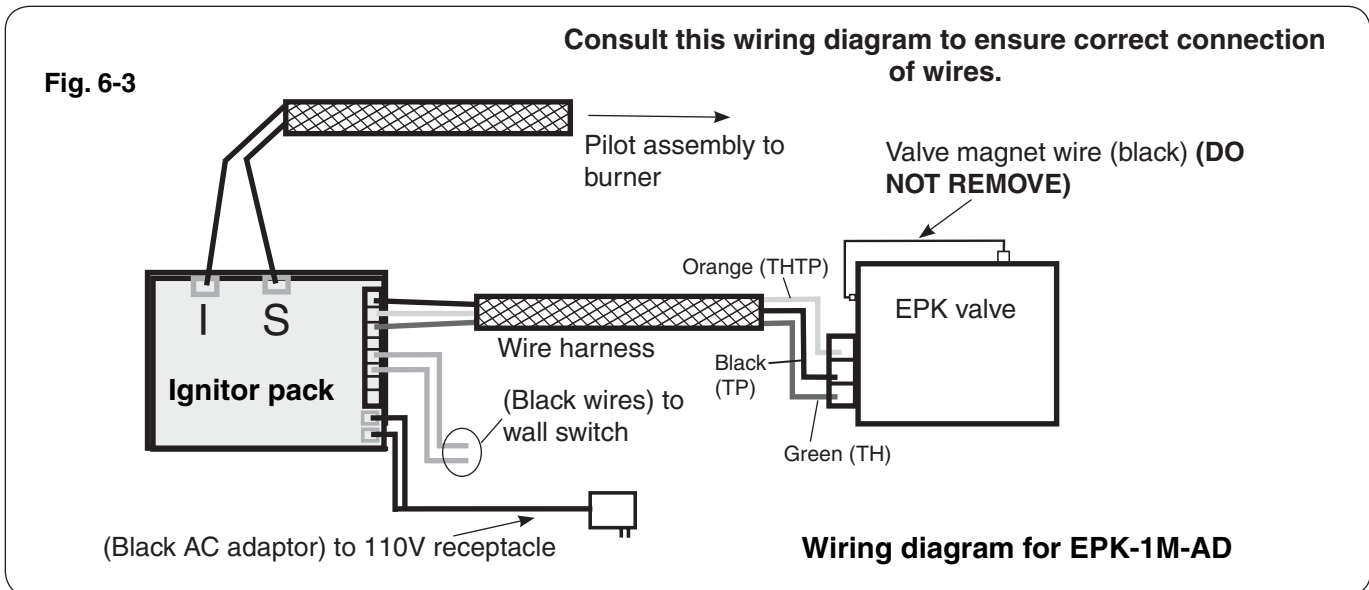
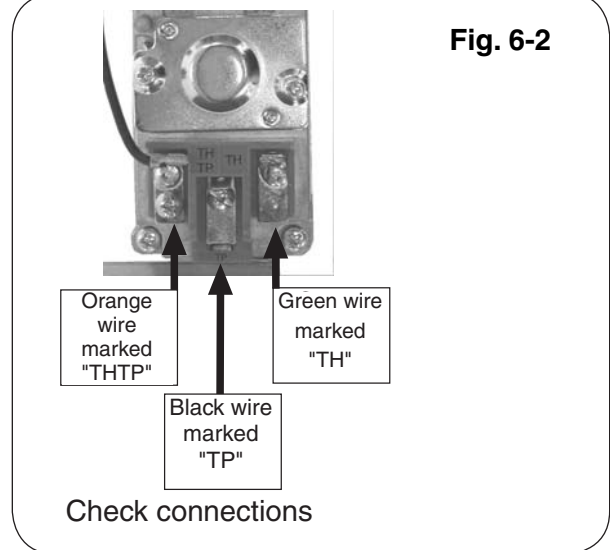
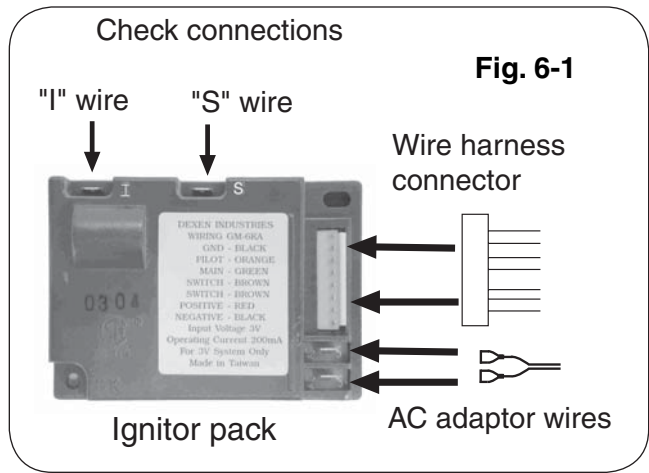

CONNECT THE IGNITOR PACK TO A WALL SWITCH

Connect the two black wires coming from the rear of the valve system to a ON/OFF wall switch (not included). Reference Fig. 7-1 for the black wires location.

CONNECT THE IGNITOR PACK TO A POWER SUPPLY

Connect the AC adaptor coming from the ignitor pack to a 110V receptacle (not included). Reference Fig. 7-2 for the AC adaptor location.

SECURE THE VALVE HOUSING

Align the housing into the opening/frame (previously made) and fasten the housing in using four screws (not provided).

Important: Be sure all wires/tubing are completely inside the opening and are not pinched or kinked when fastening the housing. See Fig. 7-3 & Fig. 7-4.

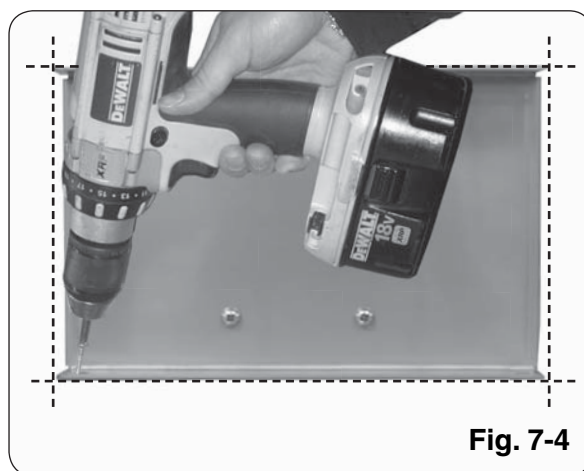
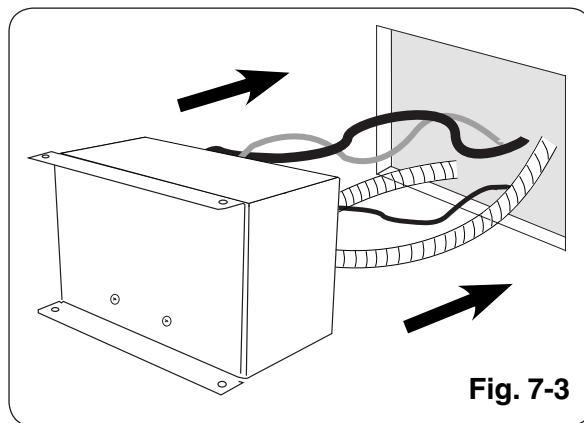
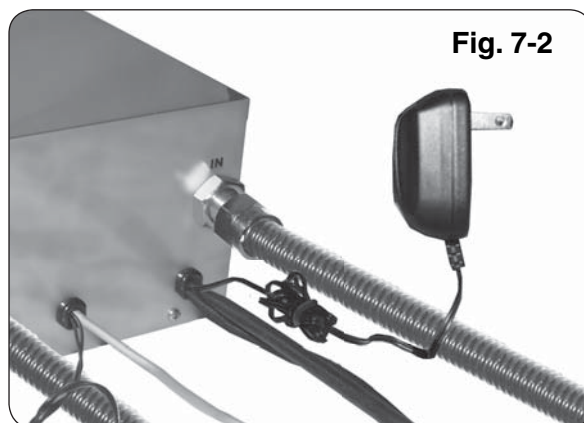
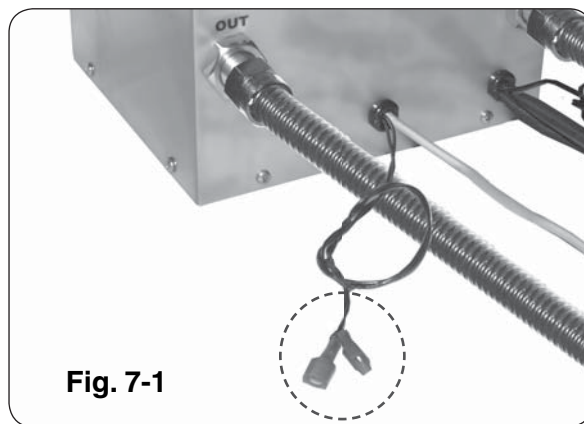

CONVERTING TO A DIFFERENT GAS TYPE

The Real-Fyre® EPK-1M-AD comes from the factory configured for natural gas. The kit includes a replacement orifice for propane configurations.

To convert this appliance from natural to propane gas or propane to natural gas, carefully follow the steps below:

CAUTION: Make sure the valve system is isolated from gas and electrical supplies before beginning.

1. Remove the pilot hood from the pilot assembly as shown in Fig. 8-1.

Note: The pilot hood is secured in place with a retainer pin. Slightly flex open (or completely remove) the pin so that the pilot hood may be easily removed.

2. Using a flat head screwdriver, unscrew the orifice from the pilot assembly (See Fig. 8-2). Locate the replacement orifice and fasten it into the pilot assembly.

3. Replace the pilot hood onto the pilot assembly. Be sure the retainer clip is secured in place.

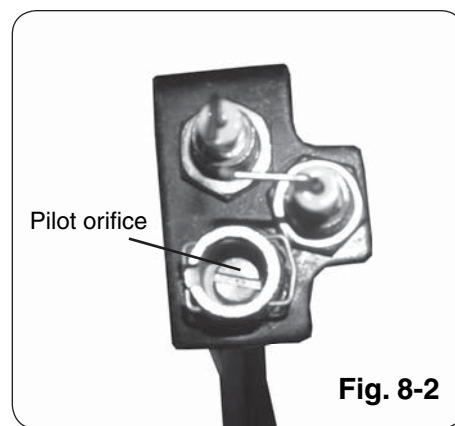
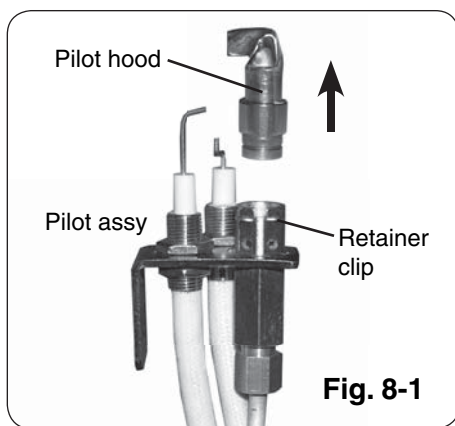

LIGHTING INSTRUCTIONS

The Real-Fyre® EPK-1M-AD has a pilot that is lit using the ignitor switch. When lighting the pilot, follow these instructions exactly.

BEFORE LIGHTING, smell all around the unit for gas. Be sure to smell next to the floor, as some gas is heavier than air and will settle on the floor. **IF YOU SMELL GAS, FOLLOW THE INSTRUCTIONS ON THE FRONT COVER OF THESE INSTRUCTIONS.**

TO LIGHT THE BURNER

1. Flip the wall switch to ON. This transmits a rapid series of sparks at the pilot head and will ignite the gas.
2. Sparks cease when the pilot flame is lit and stable. After a short time, the pilot will then light the main burner.

CAUTION: IF THE BURNER DOES NOT IGNITE WITHIN 20 SECONDS, STOP, WAIT 5 MINUTES, THEN REPEAT STEPS 1. AND 2. ABOVE.

If the pilot will not stay lit after several tries, turn the wall switch to OFF and call the service technician or gas supplier.

TO SHUT DOWN THE BURNER

Simply flip the wall switch to OFF. The gas flow will cease, and all flames (main burner and pilot) will go out.

TROUBLESHOOTING

PROBLEM	CAUSE	SOLUTION
1. Pilot will not light	<ul style="list-style-type: none"> a. Obstruction in pilot gas supply or pilot gas-supply line is kinked b. Inadequate gas supply c. Air in line 	<ul style="list-style-type: none"> a. Clear out obstruction. Replace pilot gas-supply line if kinked b. Have gas pressure checked by installer or gas supplier c. Air should clear; attempt to relight
2. No spark at pilot	<ul style="list-style-type: none"> a. Loose wires b. AC adaptor c. Faulty switch or remote (if equipped) 	<ul style="list-style-type: none"> a. Check all wires are securely in place b. Assure AC adaptor is connected to a 110V receptacle. c. Replace the pine cone unit or remote system as appropriate
3. Pilot lights, but main burner will not	<ul style="list-style-type: none"> a. Wire leads are not connected to proper valve terminals or toggle switch terminals not tight b. AC adaptor c. Defective valve 	<ul style="list-style-type: none"> a. Make sure all wire leads are tight and attached to proper terminals (see wiring diagram on p. 6, Fig. 6-3) b. Assure AC adaptor is connected to a 110V receptacle. c. Replace valve
4. Burner system not burning properly	<ul style="list-style-type: none"> a. Low flame/uneven flame 	<ul style="list-style-type: none"> a. Check for low gas pressure; should have operating pressures of 7" w.c. for natural gas, 11" w.c. for propane at manifold b. Burner should be filled completely with sand or vermiculite
5. Burner system shuts down during operation	<ul style="list-style-type: none"> a. Glass doors closed, causing excessive heat buildup b. Pilot electrode not properly set to pilot location c. Heat shield not in place 	<ul style="list-style-type: none"> a. Open glass doors b. See p. 5 (INSTALL THE PILOT ASSEMBLY TO THE BURNER) c. Place heat shield over valve. Be sure the solid black face of the shield is between the valve and the burner
6. Intermittent ignitor spark during use (main burner has been burning for well over a minute).	<ul style="list-style-type: none"> a. Embers or sand covering pilot assembly 	<ul style="list-style-type: none"> a. Clear all foreign material from around the pilot assembly

Periodically inspect the pilot assembly and valve controls and maintain them free of obstruction or debris. If the pilot flame is not blue with possibly yellow tips and does not impinge on the electrodes or if the pilot does not stay lit, contact a qualified professional service technician to service the pilot system.

NOTES PAGE

Please use this page to record any information that you may want to have at hand.

Detail A

Electrode (A)

When adjusting the spark electrode (if necessary); NEVER adjust the electrode by bending the wire. ALWAYS adjust the electrode by loosening the retainer nut(s), then adjust accordingly.

The minimum gap between the spark electrode/sensor electrode and the pilot flame hood is 1/8". The maximum is 5/32".

If the electrode ceramic is loose in the threaded barrel; the pilot assembly must be replaced.

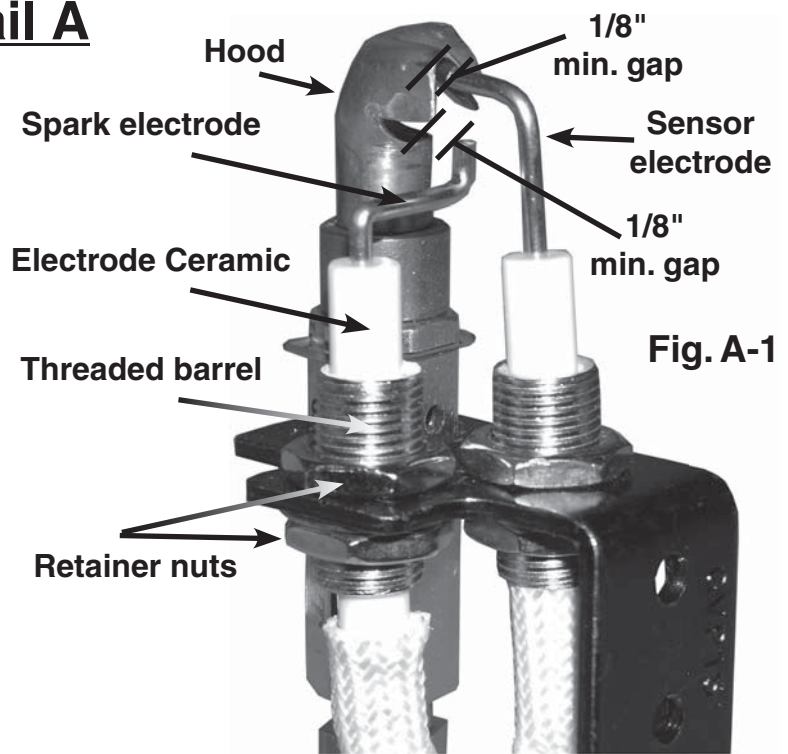

Fig. A-1

Detail B

Terminal Connections (B)

All of the connections on the control module must be properly attached. If the spade terminals are loose; inspect to ensure they correctly appear as detailed below. Use needle nose pliers to clamp down on the center/sides of the terminals if needed (to provide a tight fit.)

Spade Terminal Detail



Ensure that spade terminals (S and I) are attached securely

Ensure that multi-wire connector is properly locked in place

Control Module (DESIGN MAY VARY) (Fig. B-2)

Tighten terminals if needed

(Fig. B-3)

Detail C

(Fig. C-1)

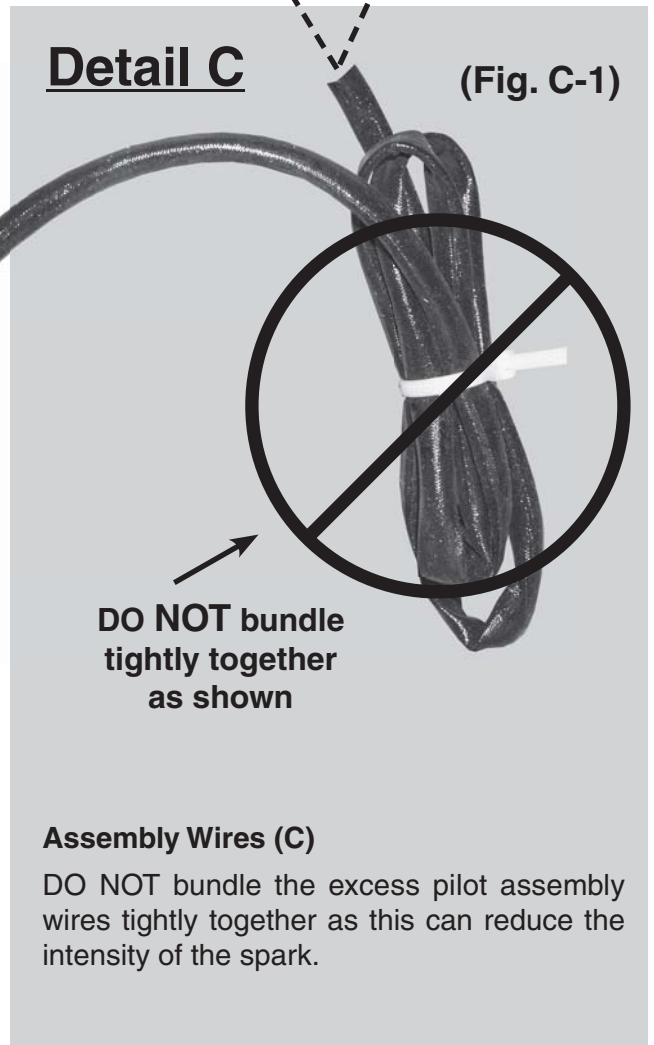

Assembly Wires (C)

DO NOT bundle the excess pilot assembly wires tightly together as this can reduce the intensity of the spark.

WARRANTY

PETERSON VENTED DECORATIVE GAS APPLIANCE LIMITED WARRANTY

All Peterson gas logs are **WARRANTED for as long as you own them (lifetime)**.

All Peterson burner assemblies are **WARRANTED for TEN (10) YEARS**.

All Peterson glass is **WARRANTED for FIVE (5) YEARS**.

SPK-26 controls are covered by a **THREE (3) YEAR "All Parts" Warranty**.

APK-17 controls are covered by a **TWO (2) YEAR "All Parts" Warranty**.

All other Peterson valves, pilots, and controls are covered by a **ONE (1) YEAR Limited Warranty (excluding batteries)**.

PLEASE KEEP A COPY OF YOUR SALES SLIP FOR PROOF OF PURCHASE

This warranty applies to the original purchaser and to single family residential use only. It commences from date of purchase, and is valid only with proof of purchase.

This warranty does not cover parts becoming defective through misuse, accidental damage, electrical damage, improper handling, lack of routine maintenance, storage, and/or installation. Product must be installed (and gas must be connected) as specified in the instructions or operator's manual, by a **qualified professional installer**. Accessories, parts, valves, remotes, etc., when used must be Peterson Co. product.

This warranty **does not** apply to rust, corrosion, oxidation, or discoloration, unless the affected component becomes inoperable. It **does not** cover labor or labor-related charges.

This warranty specifically excludes liability for **indirect, incidental, or consequential damages**. Some states do not allow the exclusion or limitation of incidental or consequential damages, so the above exclusion may not apply to you. This warranty gives you specified legal rights, and you may have other rights that may vary from state to state.

For additional information regarding this warranty, or to place a warranty claim, contact the R.H. Peterson dealer where the product was purchased.

**TO REGISTER YOUR PRODUCT ONLINE GO TO: WWW.RHPETERSON.COM,
AND CLICK ON PRODUCT REGISTRATION. THANK YOU FOR YOUR PURCHASE.**

Quality Check		Date: _____	
Leak Test: _____	Burn Test: _____	Gas Type:	Nat. / L.P.
Inspector: _____			